



Shenzhen SOSEN Electronics Co Ltd
Building A,Block 1,Pengzhanhui No.233 Zhongxin Road,Xinqiao Community Xinqiao
street, Bao'an District Shenzhen 518125, China

SosenProgrammer User Manual

V1.5



CONTENTS

1.Preface	1
1.1.Objective	1
1.2.Programmable LED driver product family	1
2.Introduction to programmer hardware and software	1
2.1.Introduction to the Programmer Panel.....	1
2.1.1.SS-PROG-LINK.....	1
2.1.2.SS-EASY-LINK.....	2
2.1.3 SS-EASY-LINK-V2	3
2.2.The programmer is wired to the LED driver	4
2.2.1 SS-PROG-LINK.....	4
2.2.2 SS-EAST-LINK.....	5
2.2.3 SS-EASY-LINK-V2	6
2.2.4 Matters needing attention.....	6
2.3.In specific cases	7
2.4 Power-on requirements for LED drivers when programming with a wired programmer	7
2.5 Prompts regarding the completion of programming Settings.....	8
3.Introduction to NFC mode LED driver programming	8
3.1 Introduction to NFC reader	8
3.2 Connect the NFC reader with the LED driver	10



4.Software installation and use	12
4.1.Operating system requirements	12
4.2.Software installation	12
4.2.1.Software decompression	12
4.2.2.Driver installation	12
4.3.Functional description of the software	13
4.3.1.Software main interface	13
4.3.2.Window area description	14
4.4.Programmer firmware upgrade	15
4.5.Online programming and offline programming	16
3.5.1. Online programming	16
3.5.2. Offline programming	17
5. Introduction to programmable LED driver functions	18
5.1.Programmable LED driver main function	18
5.2.Programmable LED driver functions explained in detail	19
5.2.1.Work Current Setting	19
5.2.2.3in1 Dimming	20
5.2.3.Timer Dimming	20
5.2.4.Software Start Adjustable	23
5.2.5.End Life Alarm	24
5.2.6.Constant Lumen Output	25
5.2.7.NTC Protection	27



5.2.8.OTP Protection	36
5.2.9.Model Parameters	38
5.2.10.DALI Application Parameters	40
5.2.11.Product Identification	41
5.2.12.DALI Memory Bank 1	41
5.2.13.DALI Dimming	42
5.2.14.ACI Dimming	43
5.2.15.Switch Dimming	44
5.2.16.Conversion Efficiency	46
5.3.Introduction to the adaptive timer function	47
5.3.1.Adaptive timer function application	47
5.3.2.Adaptive time calculation	47
5.3.3.Adaptive timer dimming	48

1.Preface

1.1.Objective

Helps users proficiency in using SosenProgrammer programming software, programmer (SS-PROG-LINK) connection, and quickly set up LED driver functions.

1.2.Programmable LED driver product family

VP series, M series, VB series, VP-H series, VA series, VA-T series, VH series, VH-E series, PA series,etc.

2.Introduction to programmer hardware and software

2.1.Introduction to the Programmer Panel

2.1.1.SS-PROG-LINK



The wiring sequence from top to bottom is: DIM-, VCC+, DIM+.

After the LED driver is connected, the programmer is powered on and can be operated by the "-" "+" "P" three keys (the "-" "+" key is used only as a fine adjustment).

The function of the button "-" is to reduce the current output by up to 10%. With one click, reduce the ratio to 0.5% of the maximum output current of the LED driver.

The function of the button "+" is to increase the current output by up to 10%; with one click, the proportion of the increase is 0.5% of the maximum output current of the LED driver,

The function of the button "P" is used for offline programming. You can write the internal model information of the programmer to the LED driver and modify the LED driver settings. When using offline programming, the internal model of the programmer must be the same as the LED driver model.

2.1.2.SS-EASY-LINK



Choose two or three wire connection according to the corresponding LED driver light adjustment number.

After the LED driver is connected, the programmer is powered on and can be operated by the "-" "+" "P" three keys (the "-" "+" key is used only as a fine adjustment).

The function of the button "-" is to reduce the current output by up to 10%. With one click, reduce the ratio to 0.5% of the maximum output current of the LED driver.

The function of the button "+" is to increase the current output by up to 10%; with one click, the proportion of the increase is 0.5% of the maximum output current of the LED driver,

The function of the button "P" is used for offline programming. You can write the internal model information of the programmer to the LED driver and modify the LED driver settings. When using offline programming, the internal model of the programmer must be the same as the LED driver model.

2.1.3 SS-EASY-LINK-V2



After connecting the LED driver properly, power on the programmer. You can operate the LED driver through the "-", "+", and "P" keys (the "-" and "+" keys are only used for fine-tuning the current).

Each time the current is slightly modified, you can unlock the fine-tuning current function by holding down the '+' key for 3 seconds and then hearing a beeping sound from the buzzer. Otherwise, the fine-tuning function will be invalid. If there is no fine-tuning current operation for 15 seconds, it will enter the locked state (unable to fine-tune the current). To fine-tune the current, you need to re-unlock. After each unlock, you can only fine-tune the current by a maximum of $\pm 5\%$. Fine-tuning the

current is only effective for the V11 model (three-in-one machine).

Press the "-" button to reduce the current output by up to 5%.Press it once, and the reduction ratio is 0.4% of the maximum output current of this LED driver.It can be used as long as the programmer recognizes the LED driver (" Run "turns green).

Press the "+" button to increase the current output by up to 5%.Press once to increase the ratio to 0.4% of the maximum output current of this LED driver. It can be used as long as the programmer recognizes the LED driver (" Run "lights green).

Press the "P" key for offline programming. It can write the internal model information of the programmer into the LED driver and modify the Settings of the LED driver. When using offline programming, the internal model of the programmer must be consistent with the model of the LED driver.

2.2.The programmer is wired to the LED driver

2.2.1 SS-PROG-LINK

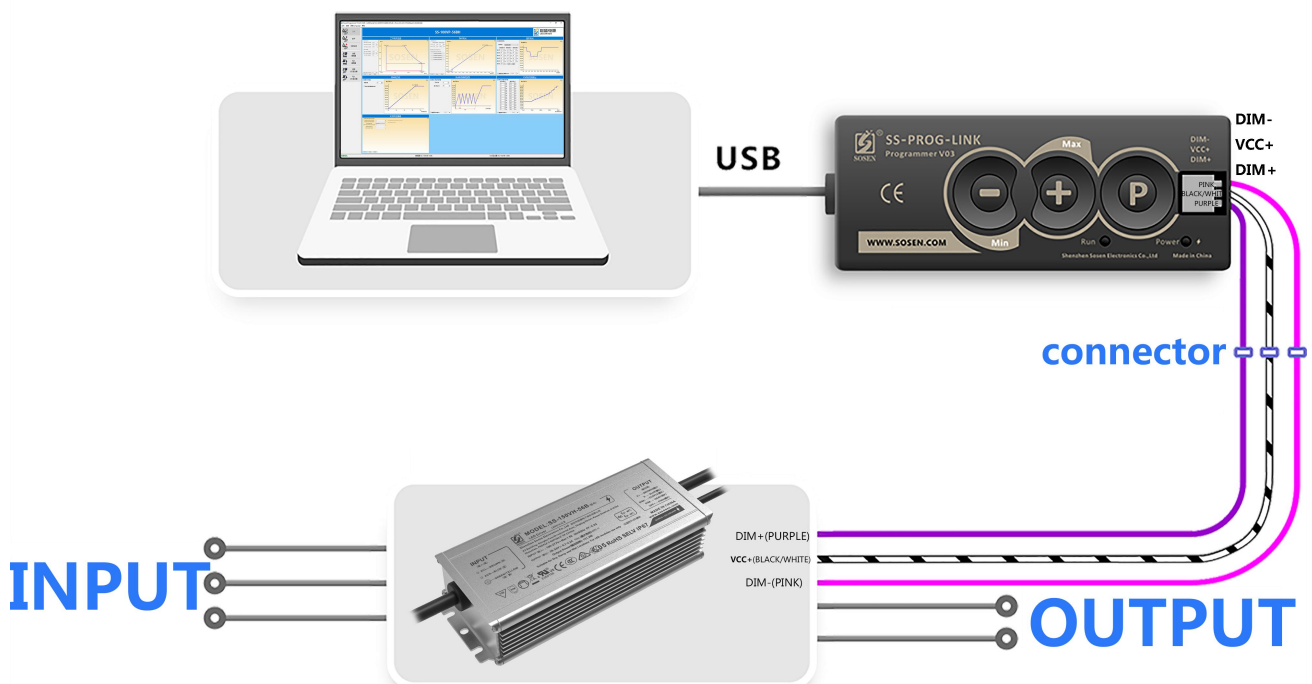

Dimming colors may change, and it is best to distinguish the wiring order according to the label of the programmer and LED driver:

“Programmer : DIM-” is connected to “LED driver: DIM-” .

“Programmer : VCC+” is connected to “LED driver: VCC+” .

“Programmer : DIM+” is connected to “LED driver: DIM+” .

2.2.2 SS-EAST-LINK

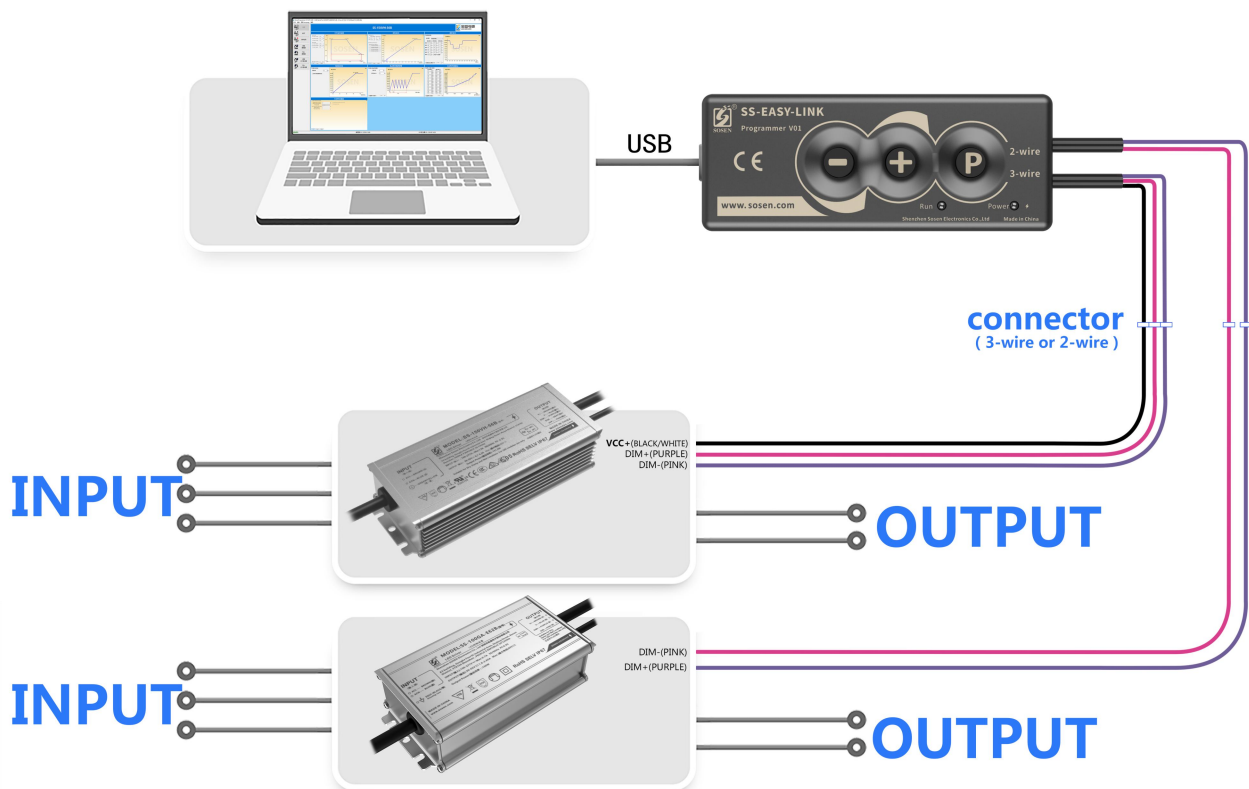

The light color may be changed, depending on the programmer and LED driver silk screen to distinguish 2 or 3 lines:

“Programmer : DIM-” is connected to “LED driver: DIM-” .

“Programmer : VCC+” is connected to “LED driver: VCC+” . (Only three wire programming has)

“Programmer : DIM+” is connected to “LED driver: DIM+” .

2.2.3 SS-EASY-LINK-V2



The color of the dimming light may change. It is best to distinguish the wiring sequence based on the silk-screen printing of the programmer and the LED driver

The DIM of the programmer corresponds to the DIM of the LED driver;

The VCC+ of the programmer corresponds to the VCC+ of the LED driver.

The DIM+ of the programmer corresponds to the DIM+ of the LED driver.

2.2.4 Matters needing attention

The programmer is connected to the computer's USB port, and the programmer recognizes the LED driver.

Connection correct: "di" sound.

Programmer connection to LED driver failed: continuous "dididi~dididi~..." sound.

Programmer does not match the LED driver software version: "didididi" sound.

2.3.In specific cases

if the AC is disconnected, it can be programmed, but the AC cannot be programmed when it is opened. Between "DIM+" and "DIM-", a capacitor in the range of 473 to 104 (47nf to 100nf) is connected in parallel. Excessive capacitance can also cause programming failures.

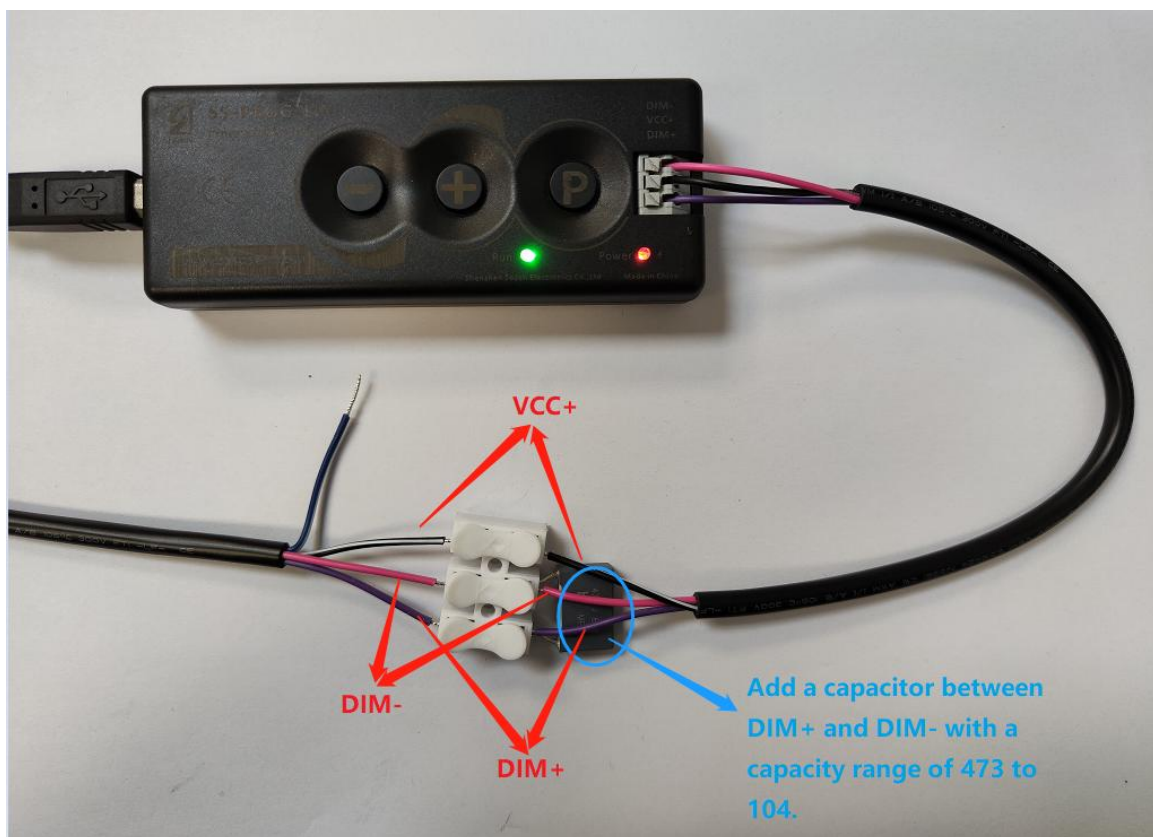

2.4 Power-on requirements for LED drivers when programming with a wired programmer

- 1.Products that require AC power-on programmability: DALI, D4i, DMX-related products
2. Programmable products that do not require AC power: 3-in-1 products

2.5 Prompts regarding the completion of programming Settings

For the drive that is currently powered on and in use, all programming functions can be realized without cutting off the power. After programming, the driver flashes to indicate that the Settings are complete. This is a normal phenomenon: -----DALI, D4i, DMX

Please confirm that the above operation steps are correct, and then perform the following operations.

3. Introduction to NFC mode LED driver programming

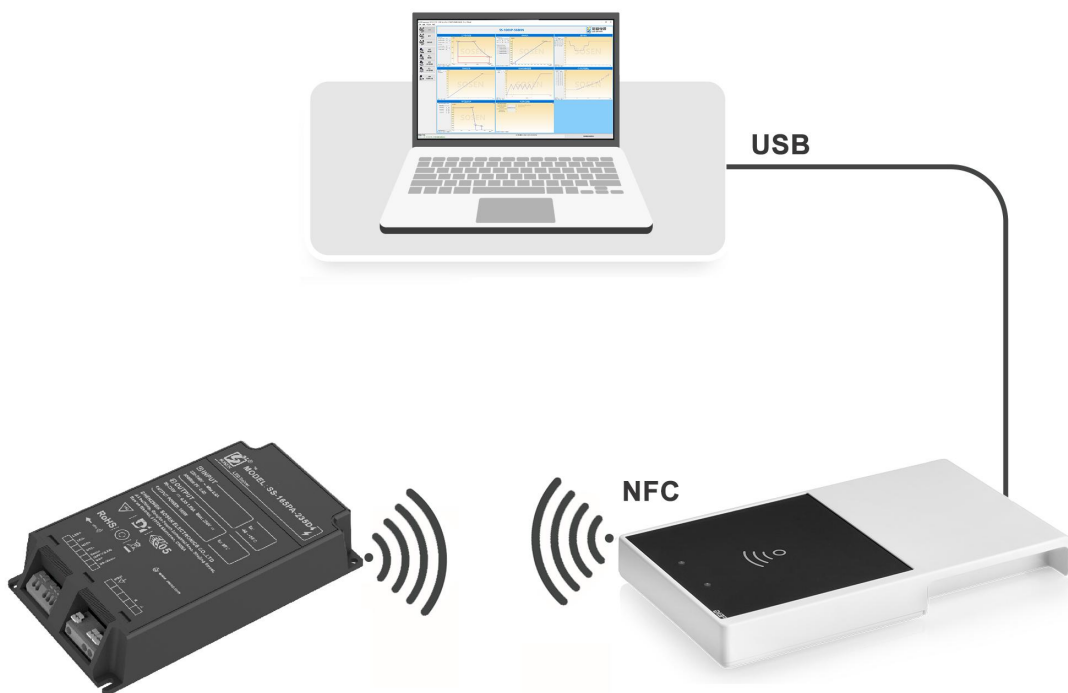

Schematic diagram of the NFC mode LED driver programming cable

3.1 Introduction to NFC reader

The models of NFC reader which SosenProgrammer software supported are as



Shenzhen SOSEN Electronics Co Ltd
Building A,Block 1,Pengzhanhui No.233 Zhongxin Road,Xinqiao Community Xinqiao
street, Bao'an District Shenzhen 518125, China

below:

1. FEIG ID CPR30+ reader.
2. FEIG ID ISC. PRH101-USB reader.



FEIG ID CPR30+ reader



Shenzhen SOSEN Electronics Co Ltd
Building A,Block 1,Pengzhanhui No.233 Zhongxin Road,Xinqiao Community Xinqiao
street, Bao'an District Shenzhen 518125, China



FEIG ID ISC.PRH101-USB reader

3.2 Connect the NFC reader with the LED driver

Connect the NFC reader to the USB port of the computer, click the "Connect" button of the software, and display "Reader connect succeed.", indicating that the reader connection is successful.



Shenzhen SOSEN Electronics Co Ltd
Building A,Block 1,Pengzhanhui No.233 Zhongxin Road,Xinqiao Community Xinqiao street, Bao'an District Shenzhen 518125, China

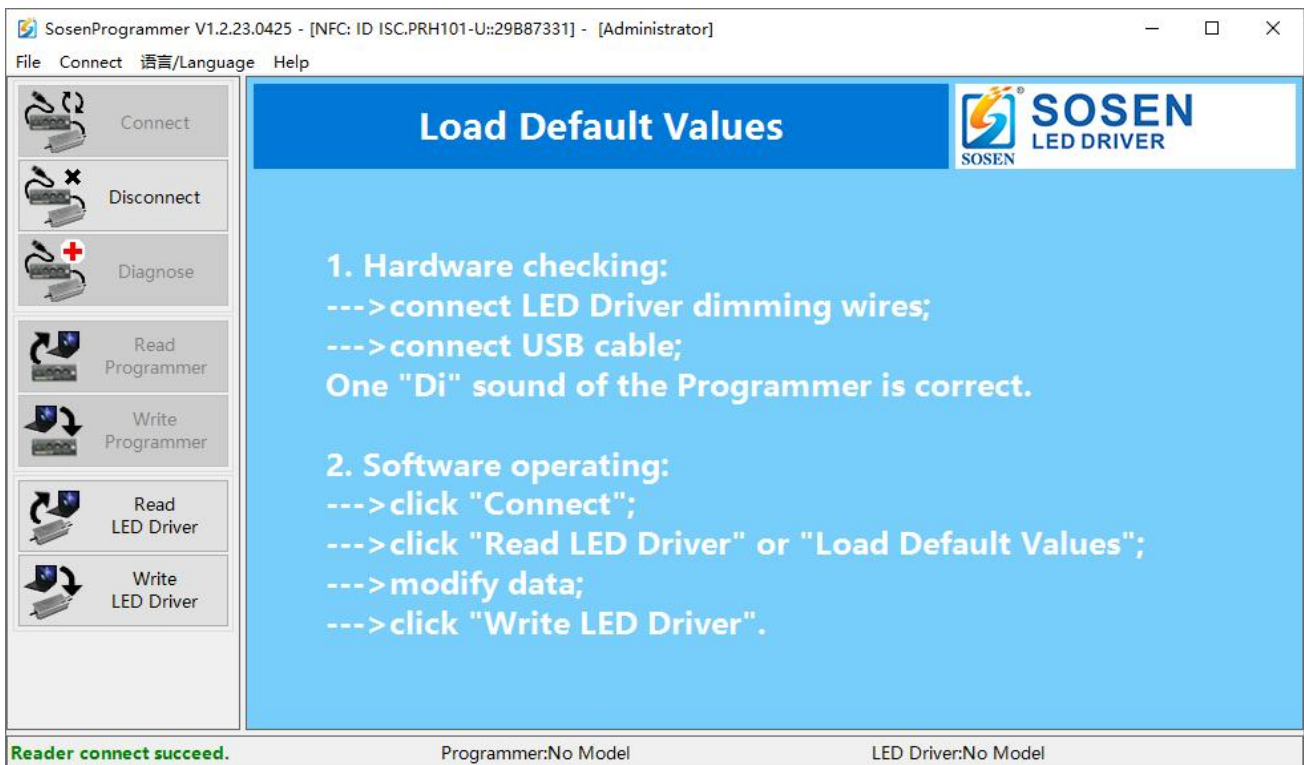

Close the NFC area of the LED driver to the NFC reader near the NFC reader, click the software "Read LED Driver" button, and display "Read LED Driver succeed.", indicating that the LED driver reading is successful.

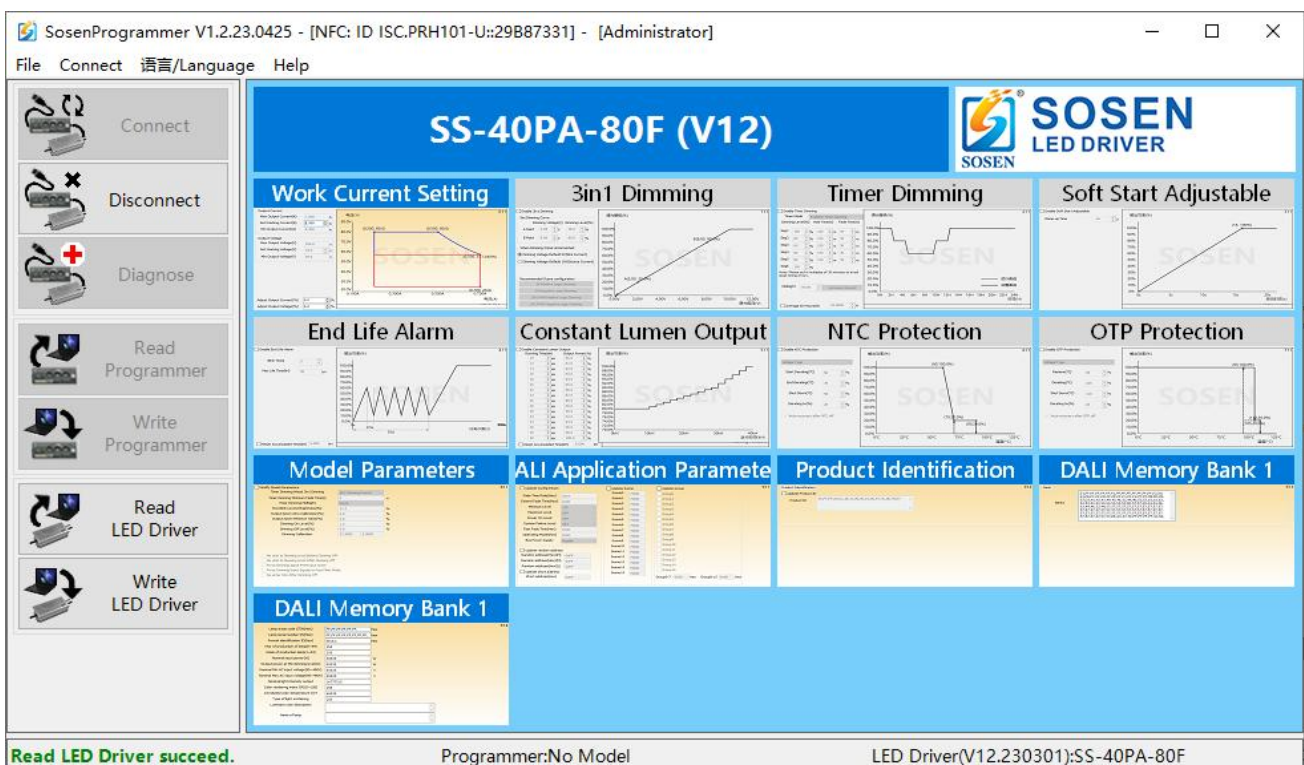

4. Software installation and use

4.1. Operating system requirements

Supports Windows 7, Windows 8, Windows 10, Windows 11.

4.2. Software installation

4.2.1. Software decompression

Extract the software package to the appropriate location, go to the software folder and send the shortcut to the desktop.

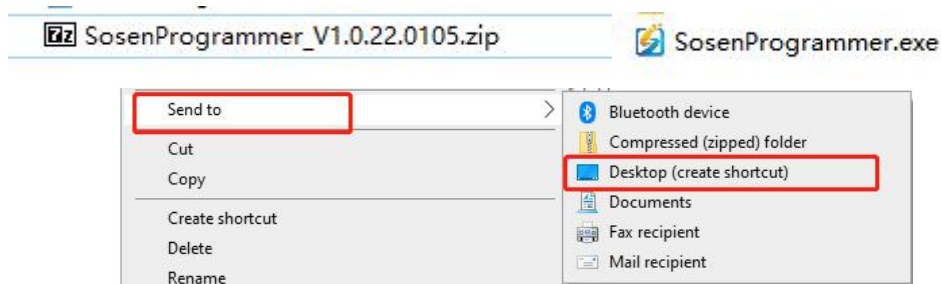

4.2.2. Driver installation

Open the SosenProgrammer software and click Connect. When the USB Serial Port (COM x) is not displayed at the port, click "Install USB Driver" and the USB driver will be installed.

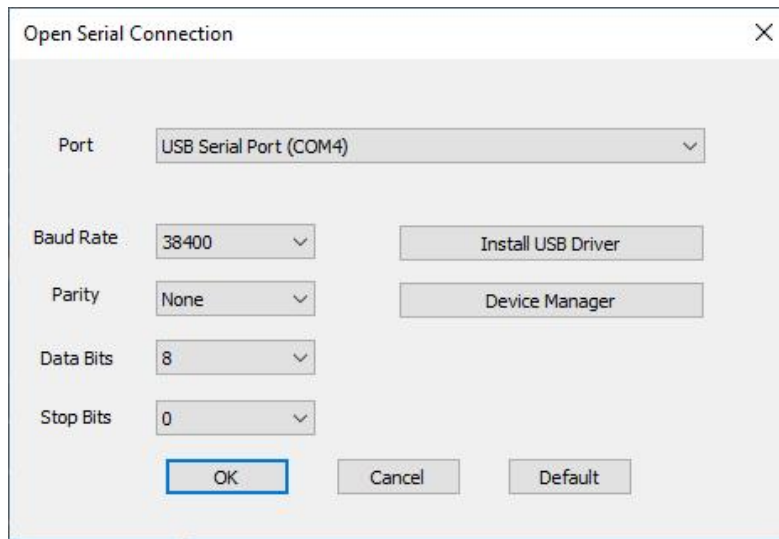

4.3.Functional description of the software

4.3.1.Software main interface

After "Read LED Driver" or "Load Default Values". Displays the features that the model has, orange for the functions that have been enabled, and gray for the functions that are not enabled.

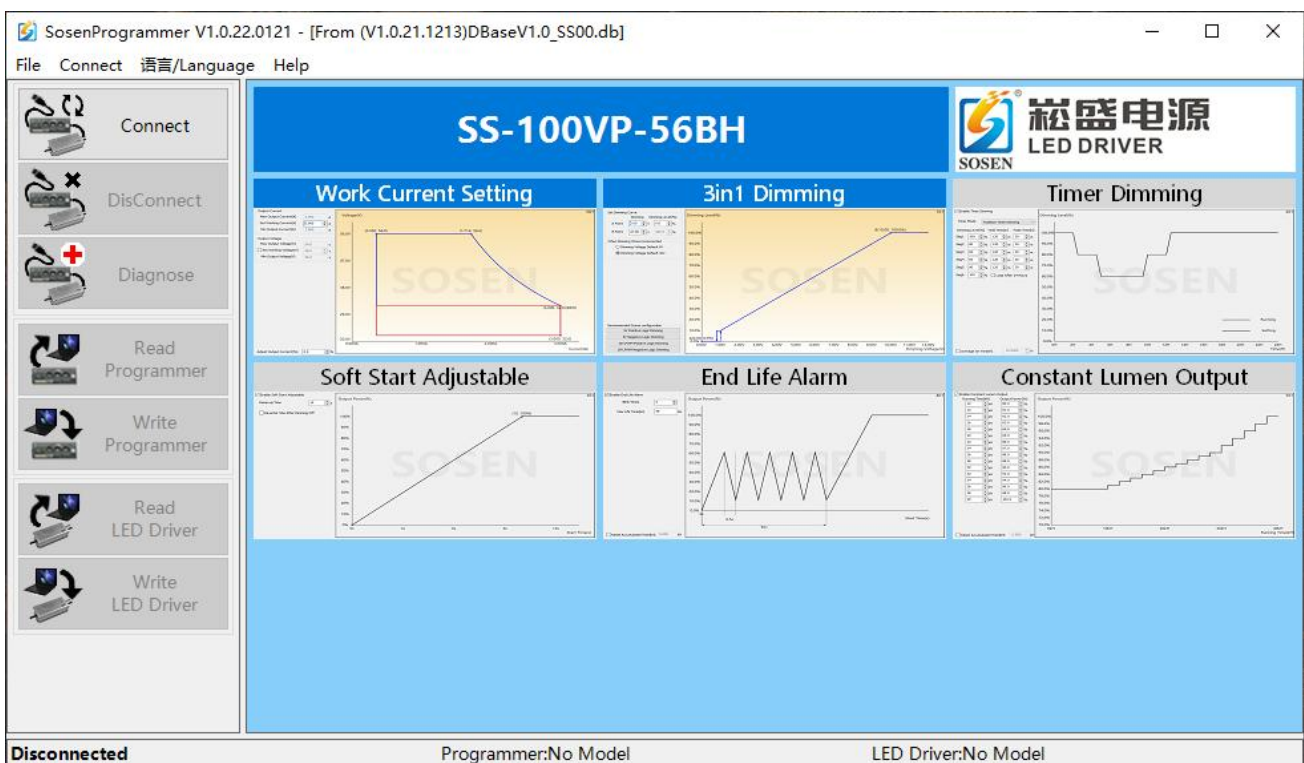

4.3.2.Window area description

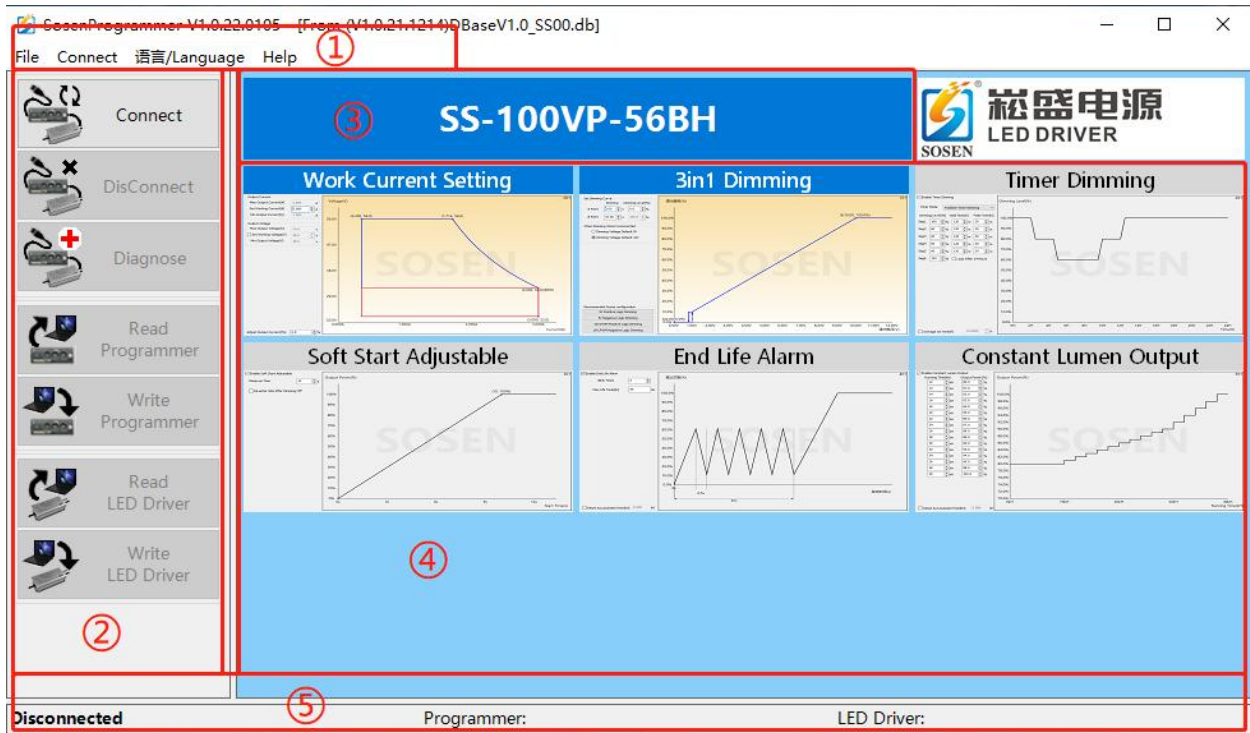

① Menu bar: With the function of saving and opening the model data file, switching languages, opening the user manual, upgrading software and so on.

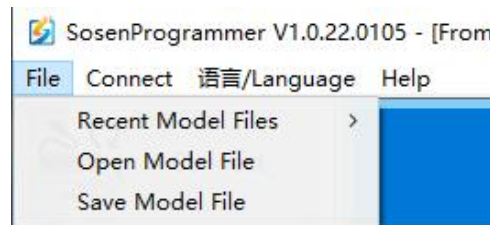

Open Model File: Loads the saved model file from a folder.

Save the model file: Save the loaded model as a data file, and the next time you can directly load the saved data by "Opening Model File".

② Operation bar: Operates the programmer and LED driver.

③ Load default values and display model names: Left mouse button opens the model list and displays the model name.

④ Function Settings: Set the parameters of the current page of this model.

⑤ Model name display: Displays the operating status, the model saved by the current programmer and the model of the LED driver access.

4.4.Programmer firmware upgrade

(1) Automatic detection of upgrades: the programmer is connected to the LED driver and then connected to the computer. Click "Connect" and the SosenProgrammer software will automatically detect the programmer version and pop up the box to indicate if an upgrade is required. When a new version of the programmer is available, a box prompts you to upgrade the new version.

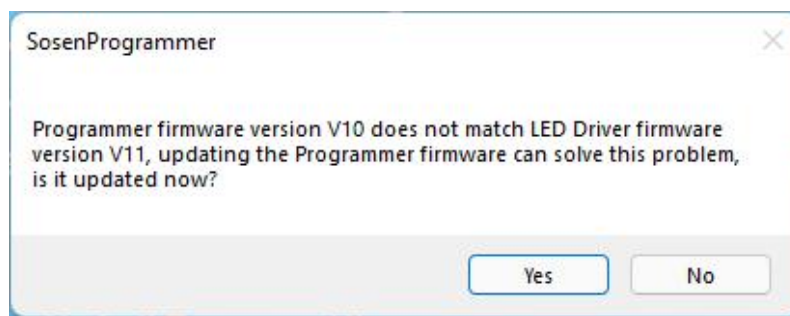

(2) Manual upgrade: Plug the programmer into the computer, connect to the SosenProgrammer software, click "Diagnose", click to "Upgrade Programmer Firmware", click "Select Firmware". In the "SosenProgrammer_V1.0.xx.xxx \ Firmware" folder, find the firmware package that needs to be upgraded, click "Start Upgrade", and wait for the upgrade to complete (do not power off the programmer during the upgrade process).

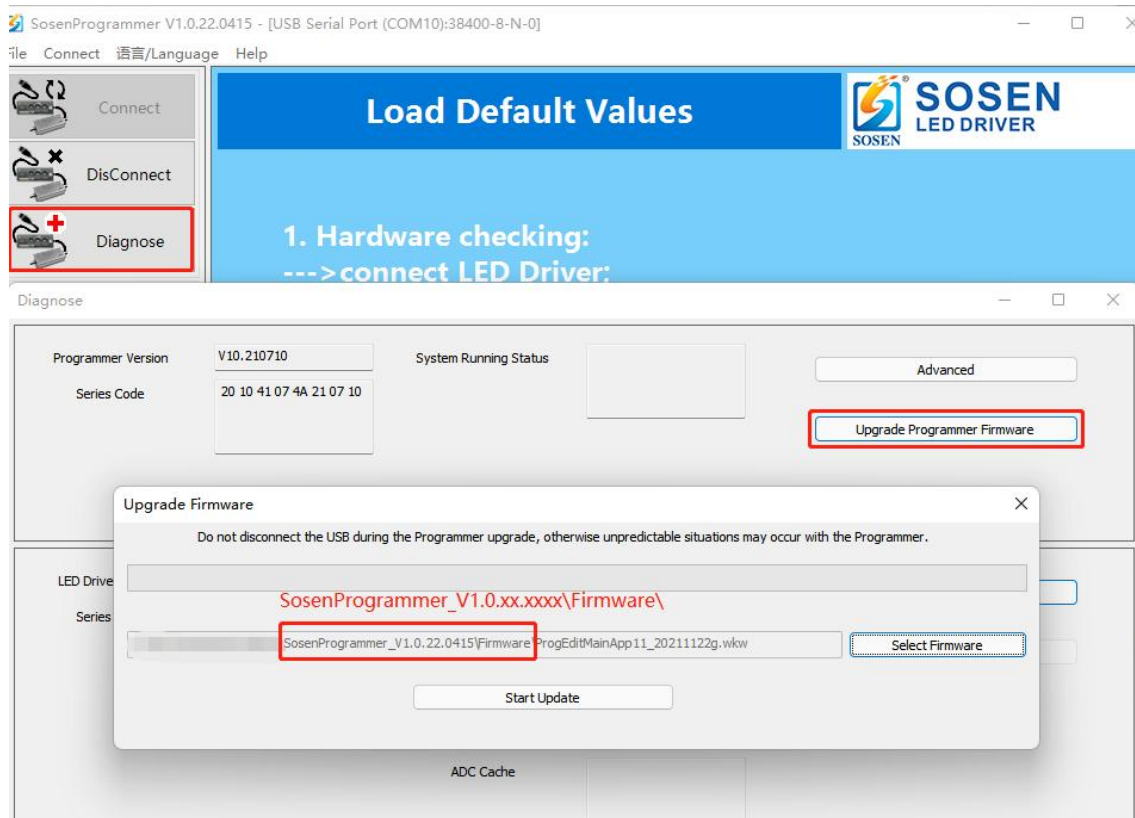

4.5. Online programming and offline programming

When writing to the LED driver, make sure that the model selected is the same as the model of the connected LED driver. If the model is different, the programmer will refuse to program and report an error.

3.5.1. Online programming

Online programming operation method: **Open “ SosenProgrammer ” -> Connect -> Read LED Driver / Load Default Values -> modify data -> Write LED Driver**

Connect: Click "Connect", the serial connection dialog box will pop up, select the correct COM port (USB Serial Port (COM x)).

Read LED Driver: Reads all data from the connected LED driver and refreshes the SosenProgrammer software interface.



Load Default Values: If you want to restore the default parameters of the model, you can click "Load Default Values", select the correct model, and load the default data into the software interface.

Write LED Driver: Write the set working current data, 3in1 dimming, timer dimming and other parameters to the LED driver.

Note: When writing to the LED driver or reading the LED driver, do not set the SosenProgrammer software parameters, there may be incorrect parameters written or read.

3.5.2. Offline programming

① Make an offline programmer

Making offline programming method: **Open “ SosenProgrammer ” -> Connect -> Read LED Driver / Load Default Values -> modify data -> Write Programmer**

The first four steps are the same as online programming, and the last step is to write Programmer to prepare the offline Programmer of this model.

② Batch programming

Offline programming method: **Made offline programmer -> USB power supply -> press the "P" key to program**

The model number of the writer programmer must be the same as the model of the LED driver for the write to succeed. If the models are different, the programmer will refuse to program and alarm.

Press the "P" key to program the LED driver. After programming is complete, replace



the other LED drivers that are ready for programming and repeat this operation.

5. Introduction to programmable LED driver functions

5.1. Programmable LED driver main function

- (1) Work Current Setting (Current and voltage can be set)
- (2) 3in1 Dimming (Compatible with PWM dimming, 0-5V, 0-10V, Resistance dimming, etc.)
- (3) Timer Dimming (Traditional Timer Dimming, Self-Adapt-Midnight Timer, Self-Adapt-Percentage Timer)
- (4) Software Start Adjustable (turns on gradually brightening)
- (5) End Life Alarm (Reminder to replace the LED driver)
- (6) Constant Lumen Output (LED lamp pearl attenuation compensation)
- (7) NTC Protection (LED module over-temperature protection function)
- (8) OTP Protection (LED driver over-temperature protection function)
- (9) DALI Application Parameters (Configure DALI application parameters for LED driver)
- (10) Product identification (Product identification parameters of LED driver)
- (11) DALI Memory Bank 1 (Set DALI block 1 parameters)
- (12) DALI Dimming (Set DALI control parameters)
- (13) ACI Dimming (LED driver undervoltage protection)
- (14) Switch Dimming (Multi-gear dimming)
- (15) Conversion efficiency (Current power calibration)

Note: The power supply of the company distinguishes between DALI models and 3-in-1 models, and the following function details will be distinguished.

5.2.Programmable LED driver functions explained in detail

5.2.1.Work Current Setting

The output current of the LED driver can be freely adjusted, and the parameters obtained by the LED driver are read by the programmer and displayed on the programming software interface. Modify the current parameter at the set operating current to change the output current of the LED driver. Modifying the parameters at the set operating voltage can reduce the operating voltage of the LED driver.

Fine-tune the output current, for the programmed current data and the actual output current of the LED driver error, the input error ratio, you can get the accurate current parameters (according to the maximum output current of the LED driver is the calculation base).

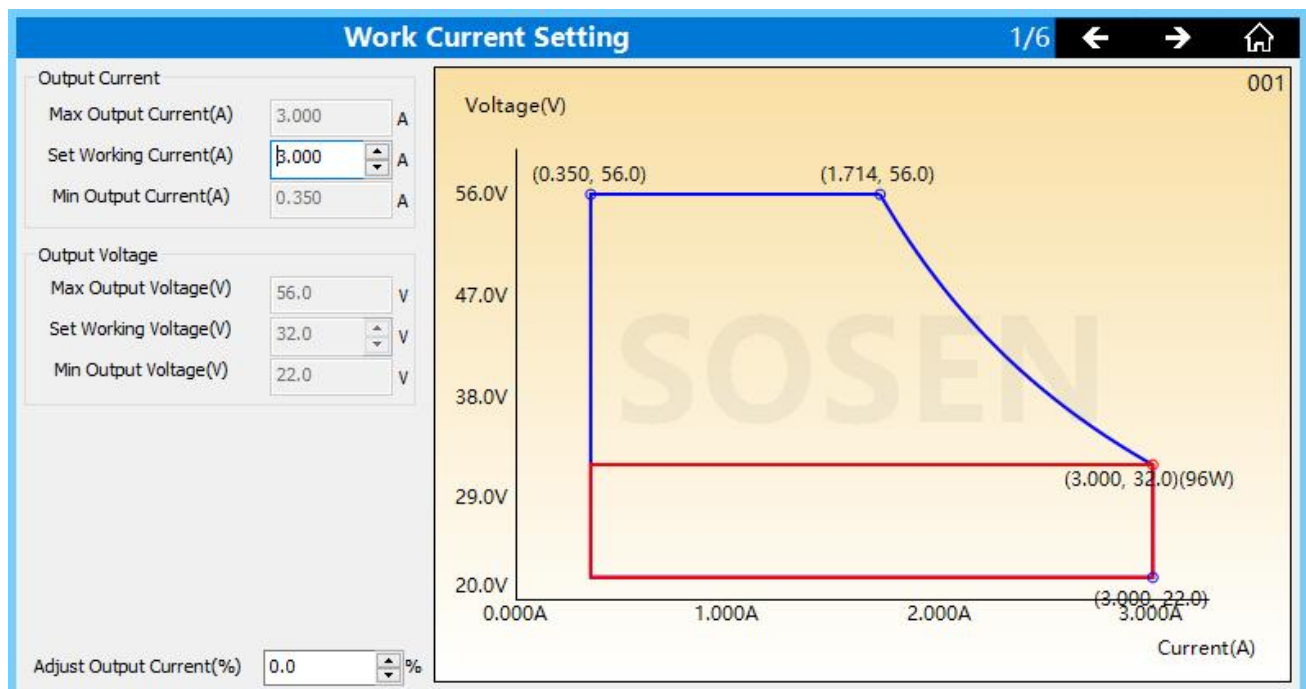

5.2.2.3in1 Dimming

Set DIM dimming (PWM dimming, resistance dimming integrated into 0-10V dimming).The dimming voltage of point A and point B can be adjusted according to the actual use.Adjustable light output voltage can be set when the adjustable light is suspended (only some hardware support).Set the dimming level of point A to the lowest level brightness that can be dimmed (If the dimming level of point A is set to 100%, it will not be dimmed).

The off voltage and on voltage are set on the Model Parameters page.

Note: This function is only available for 3-in-1 power supply, as shown below:

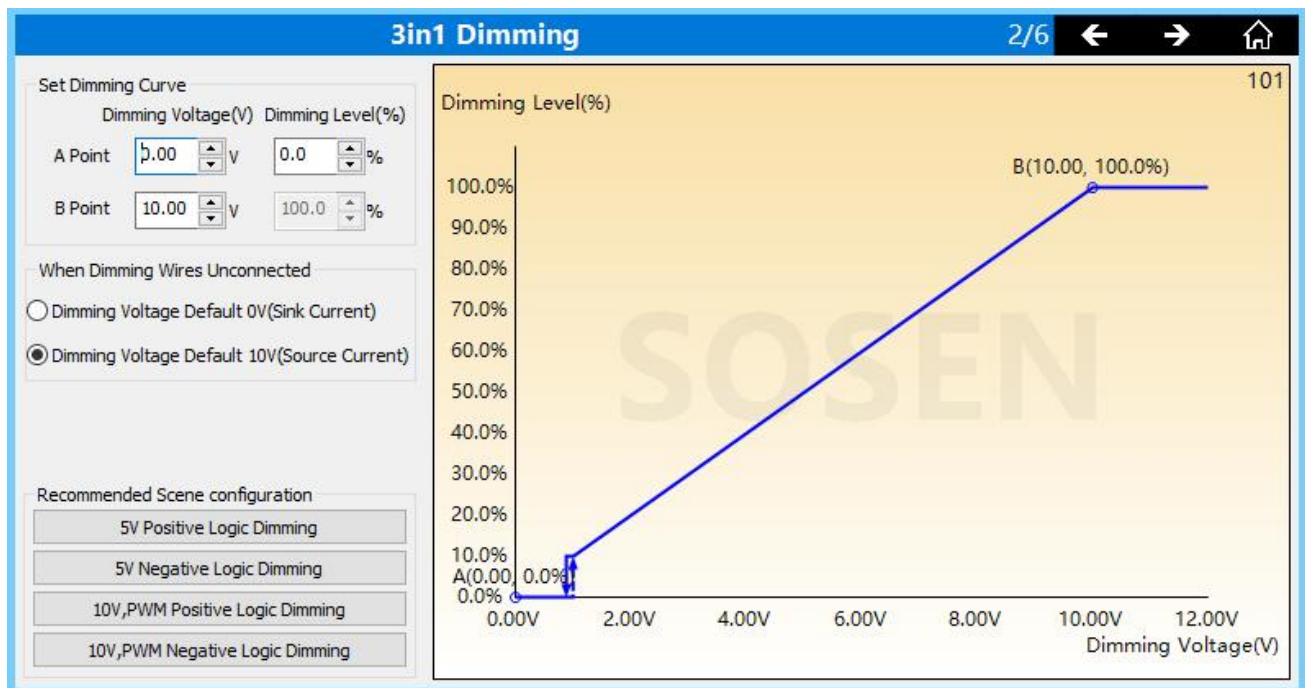

5.2.3.Timer Dimming

Automatic conversion of daylight and winter time, adaptive midpoint alignment, adaptive percentage, traditional timing dimming.The time control dimming

percentage can be set by setting each period of time.

Traditional Timer Dimming: After the LED driver is powered on, it works according to the set dimming curve (adding a gradient time can slowly change between different dimming levels to prevent sudden changes in brightness and cause glare).

DALI power dimming curve consists of eight sections, including the beginning of the gradual transition time into the next section of the curve holding time (such as the beginning of the gradual transition time into the first section of the curve holding time), as shown below:

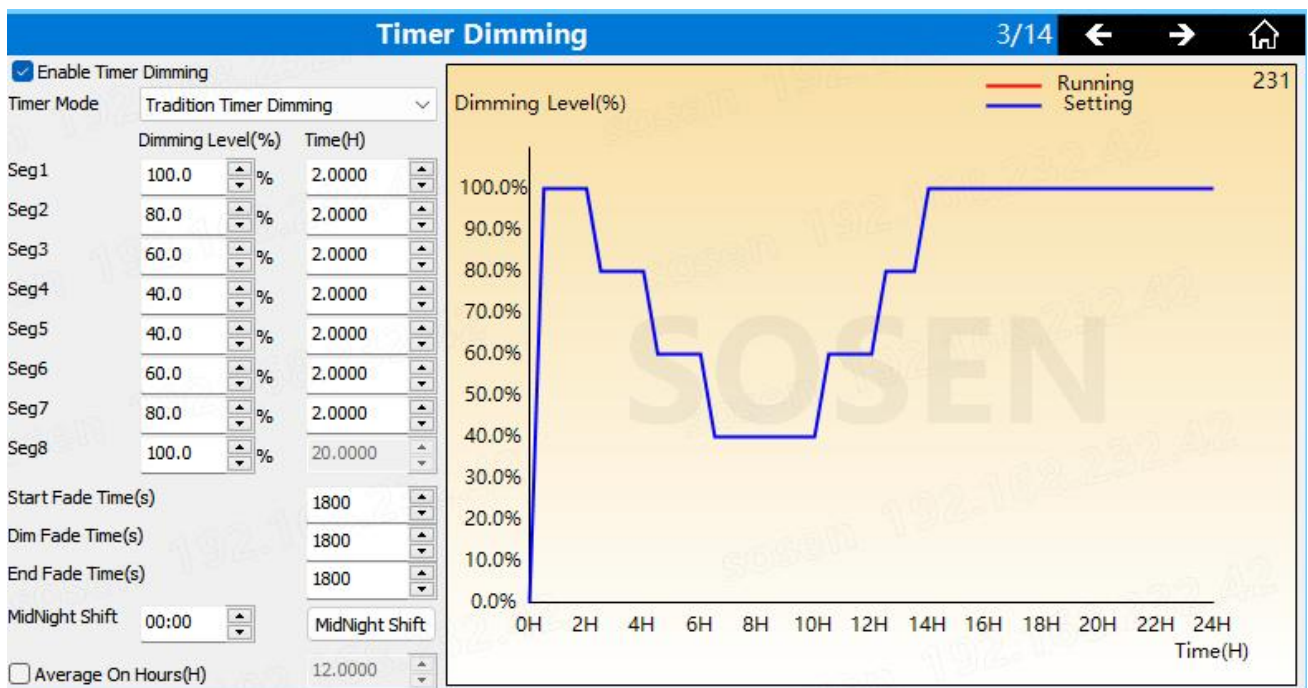

The dimming curve of the three-in-one power supply consists of six sections, without a starting section of the gradual time, and the gradual time is not incorporated into the curve holding time. As shown below:

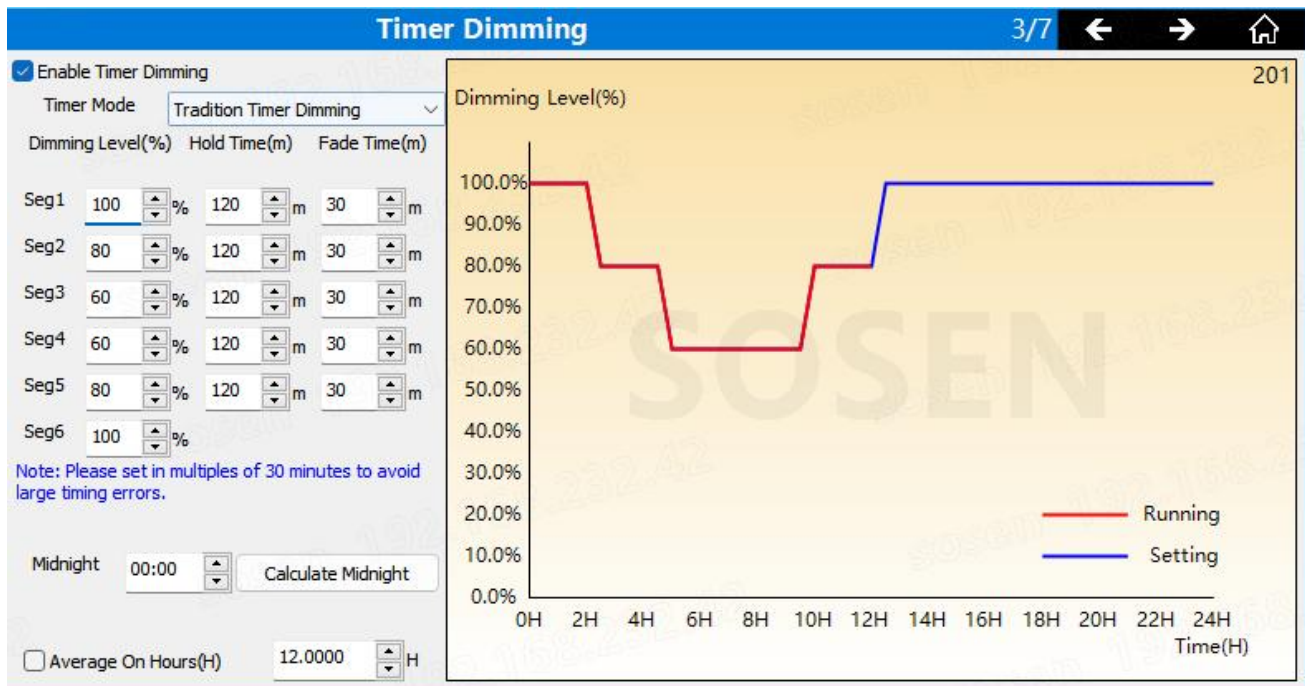

Self-Adapt-Midnight Timer: Timing mode Select Adaptive midpoint dimming. Adaptive midpoint dimming runs according to the auto-calculated adaptive cycle time based on the initially set dimming curve. The user can reset the adaptive cycle.

Self-Adapt-Percentage Timer: Timing mode Select Adaptive midpoint dimming. Adaptive percentage dimming runs according to the automatically calculated adaptive cycle time based on the initially set dimming curve. The user can reset the adaptive cycle.

Notes:

If the power is not turned on or off once on the same day, the power supply will continue to operate at the last brightness level throughout a complete time control cycle.

5.2.4. Software Start Adjustable

The LED driver boot time can be set in the user interface. Applicable scenes such as road lighting, tunnel lighting, square lighting, stadium lighting, plant lighting, etc., can effectively prevent the lighting process, the lamp suddenly lit up, causing glare to people, causing traffic accidents. When the multi-LED driver is opened at the same time, it can effectively prevent the boot moment, the AC line load is too large, and achieve the effect of protecting the AC line.

The SSA dimming time of DALI power supply ranges from 1s to 63 minutes. As shown below:

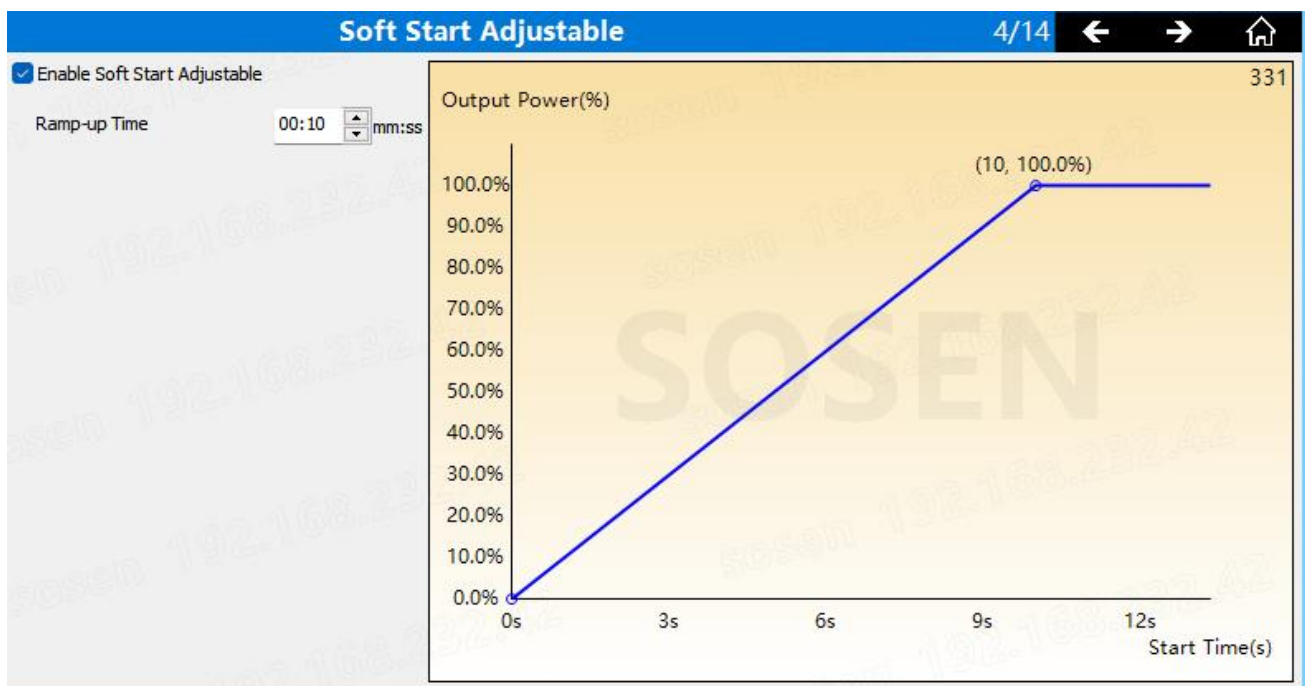

The SSA dimming time range of the three-in-one power supply ranges from 1s to 127s. As shown below:

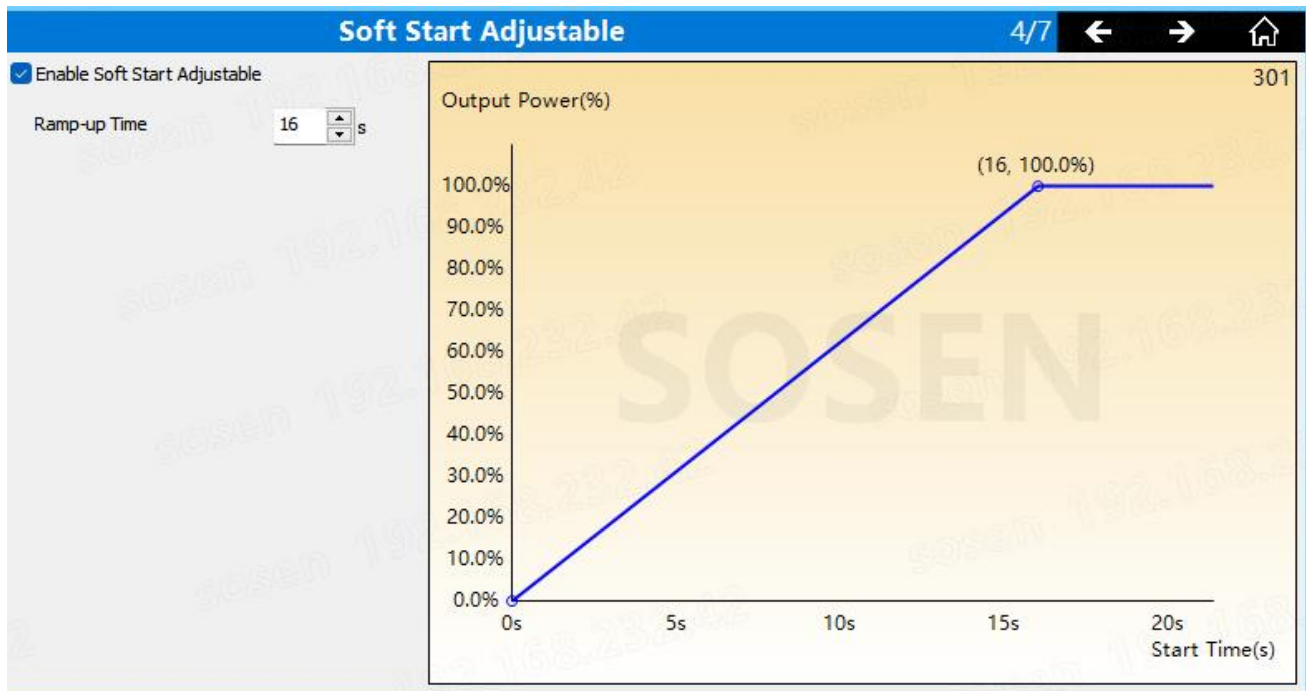

5.2.5.End Life Alarm

The user interface can set the maximum life time of the LED driver, such as the life of 50KH, when the lighting time accumulates to 50KH, each time the lamp is powered on, it will flash to remind the user to replace the LED driver. At the bottom of the interface, the accumulated time can be reset. If the reset accumulated time is 50KH, the light will blink.

DALI power supply ELA limit blinks 4 times, the model characteristic parameters can be checked ELA life warning and turn off the output, as shown in the figure below:

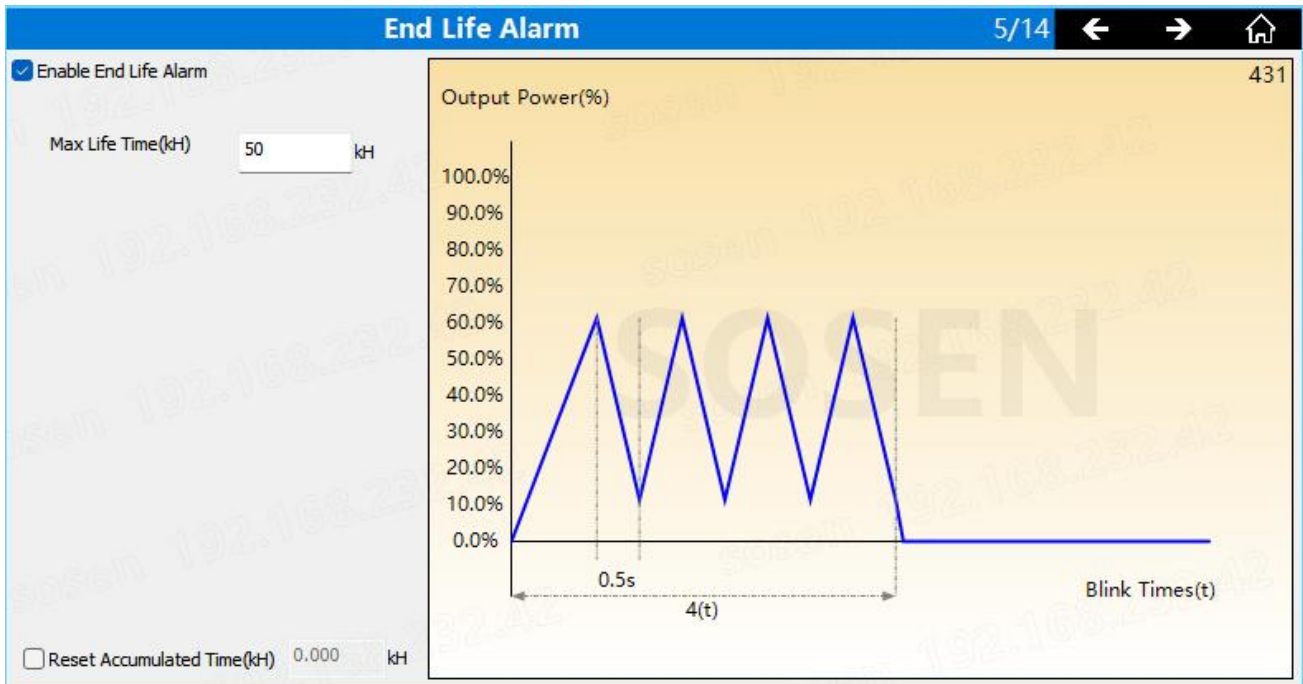

The ELA blinking times of the 3-in-1 power supply can be 1 to 7 times, and the function is turned off after no ELA blinking, as shown in the following figure:

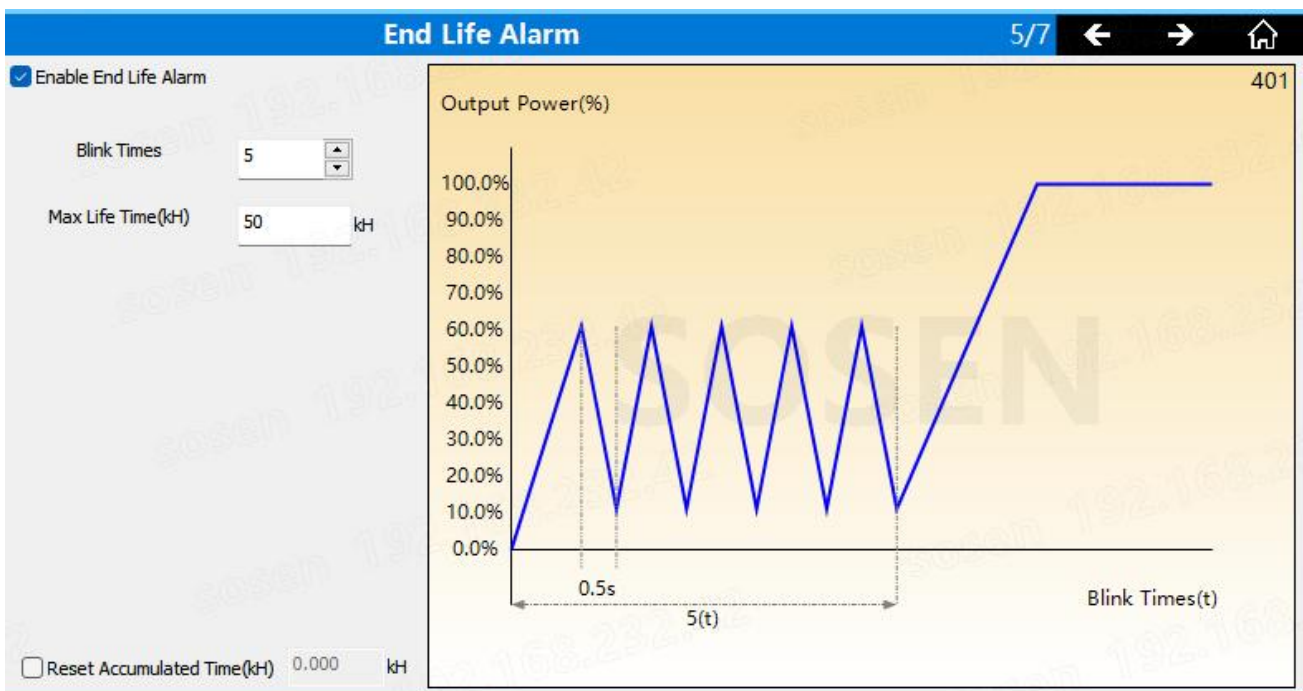

5.2.6.Constant Lumen Output

Light decay compensation function, according to the LED lamp light decay curve, in the life cycle of the lamp, by gradually increasing the output current, to achieve a



constant output of LED luminous flux, the overall luminous effect remains unchanged.

3-in-1 Power CLO user interface is as follows:

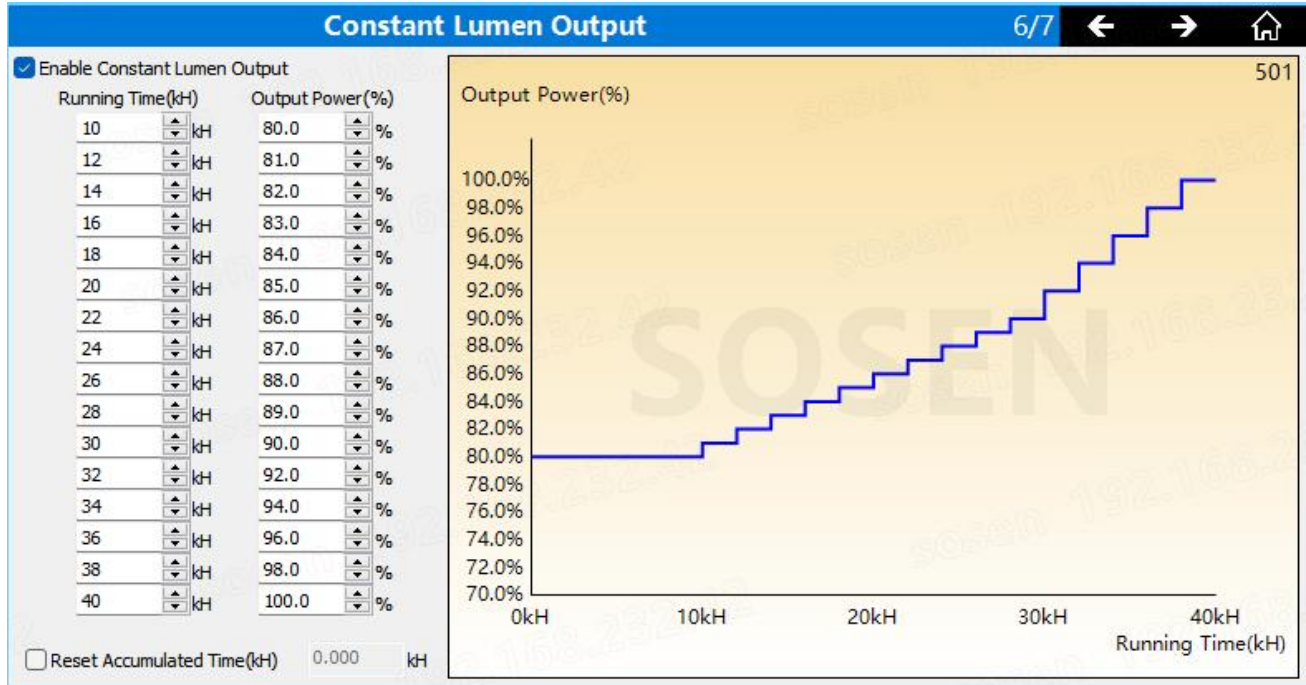

DALI Power CLO user interface is as follows:

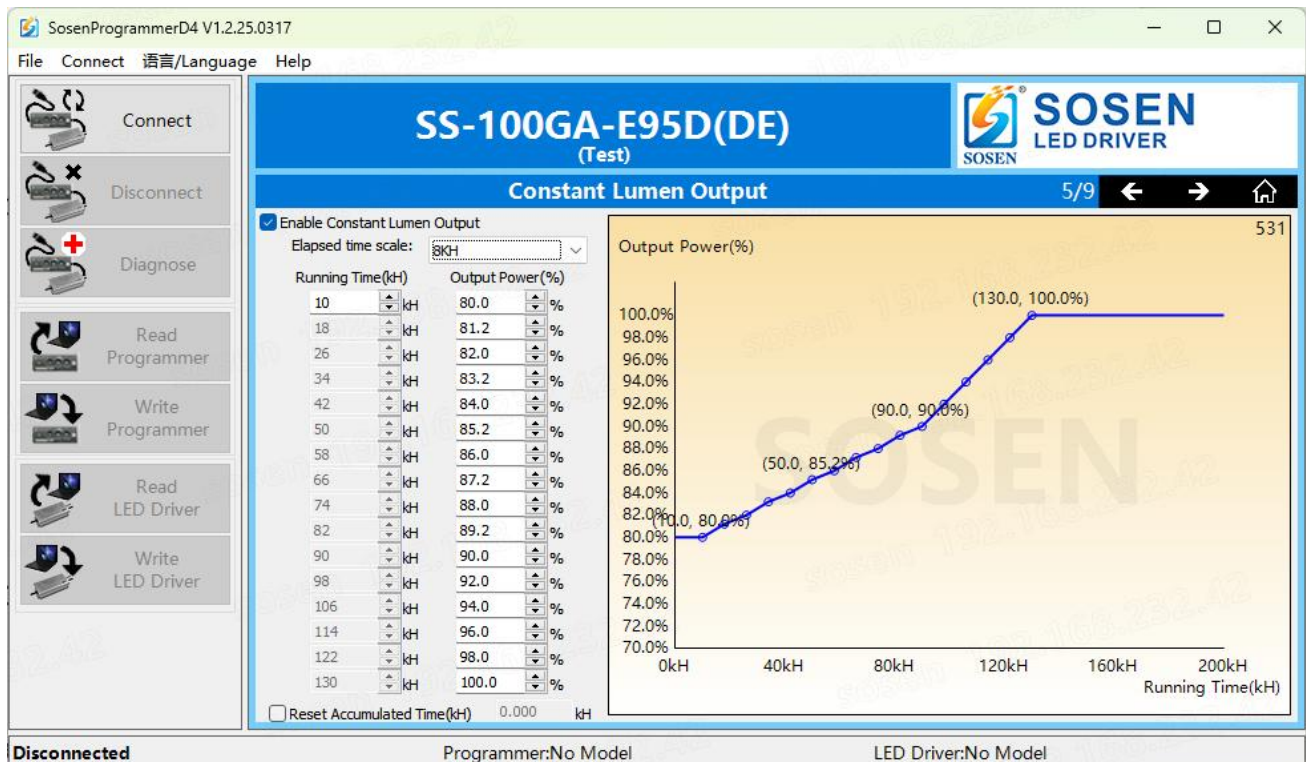

The run time scale refers to the run time step length, which can be set to



1KH,2KH,4KH,8KH.The entire operating life can be set to a maximum of 15~246KH.The minimum output power of the first level is 49.6%, and the maximum output spacing difference between adjacent levels is 6%.The output power of the first level is 0.8%/ scale, and the remaining levels are 0.4%/ scale.Values entered by the user, values outside the scale value, will be corrected.If the first level output power is set to 82%, the window will be changed to 82.4%.

5.2.7.NTC Protection

At the LED driver end, a line is drawn to the NTC temperature switch sensor to feed the temperature on the LED module back to the internal controller of the LED driver.

Note: The LED driver hardware must support the NTC function.

1. Currently LED driver NTC functions are divided into two categories:

a.The NTC functions supported by the a.D4i model are shown in the functional interface shown in Figure 1.Models that support this feature include the 22PA-32F.Note: DALI2 models do not have NTC function.

b.The NTC functions supported by the 3-in-1 model are shown in the functional interface shown in Figure 2 and Figure 3.This model supports two types of NTC logic, which can be selected on the Model Characteristics page.Models that support this feature include the 1200NP-M430BHN.

2. NTC function on D4i models:

a. Three types of thermistors are supported: 10K Ω _B3950K, 10K Ω _B3435K, and



10K Ω _B3380K. A thermistor "Temperature Value - Resistance Value" mapping table is attached at the end of this section.

b. Operation Logic:According to the parameter setting shown in Figure 1, as shown in the blue line, when the temperature is lower than 60°C, the output power is 100%; when the temperature is greater than 60°C and less than 70°C, the output power runs according to the slanting line between 60°C and 70°C, and the output power will be accompanied by this lowering and raising as the temperature increases and decreases; when the temperature is greater than 70°C, the output power will be lowered to 10%, and keep at 10%; when the temperature is greater than 90°C, the output power will be turned off. ; when the temperature is greater than 90°C, the output will be turned off. Alternatively, setting the shutdown temperature to less than or equal to the temperature at which the end derating occurs will turn off the shutdown function and neither shutdown.

c. After the NTC is turned off, the output can be restored according to 3 different recovery conditions. The first condition is when the temperature drops to the end derating temperature and the output is restored. The second condition is when the LED driver is re-powered and the output is restored. The third condition is when power is restored after reprogramming the LED driver. The output power level specified at the time of end derating will be restored.

3. NTC function for 3-in-1 models

- a. Supports two types of NTC runtime logic: runtime logic 1 and runtime logic 2.
- b. Two types of thermistors are supported: 10K Ω _B3950K, 10K Ω _B3435K. A



thermistor "Temperature Value - Resistance Value" mapping table is attached at the end of this section.

c. Running logic 1: According to "Model Characteristic Parameters" interface - "NTC running logic" option, select "Running logic 1", set the parameters as shown in Figure 2, as shown in the blue line, when the temperature is below 60°C, the output power is 100%; when the temperature is greater than 60°C and less than 70°C, the output power will run according to the slant line between 60°C and 70°C. As shown in the blue line, when the temperature is lower than 60°C, the output power is 100%; when the temperature is greater than 60°C and less than 70°C, the output power runs according to the slanting line between 60°C and 70°C, and the output power will be accompanied by the lowering and raising as the temperature increases and decreases; when the temperature is greater than 70°C, the output power will be reduced to 20% and kept at 20%; when the temperature is greater than 90°C, the output will be turned off; after NTC is turned off, you can choose to restore the output according to the checkbox option, and then the output will be restored. The output can be restored or not according to the checkbox option. In addition, setting the shutdown temperature to less than or equal to the temperature of the end derating or unchecking the shutdown option will turn off the shutdown function, neither shutdown.

d. Running logic 2: According to "Model Characteristic Parameters" interface - "NTC running logic" option, select "Running logic 2", set the parameters as shown in Figure 3, as shown in the blue line, when the temperature is lower than 70°C, the output power is 100%; when the temperature reaches or greater than 70°C, a derating



event will be triggered, and the output power will be derated by 5% from the current actual level. As shown in the blue line, when the temperature is lower than 70°C, the output power is 100%; when the temperature reaches or is greater than 70°C, a derating event will be triggered, and the output power will be derated by 5% from the current actual level, for example, if the current output power level is 100%, then the output level will be derated to 95%, and if the temperature is still greater than or equal to 70°C after a 2-minute time interval, a derating event will be triggered again, and the interval between two derating events will be at least 2 minutes. If the temperature is still greater than or equal to 70°C, a derating event will be triggered again. When multiple derating events occur, the output level will be reduced to a minimum of 20% and remain at 20%; regardless of the current output level at which the output level is at, when the temperature drops to 60°C, the output level will return to 100%. When the temperature is greater than or equal to 90°C, the output will be turned off; after the NTC is turned off, the output level will be restored to 20% when the temperature drops to 70°C; the output can be restored or not according to the checkbox. In addition, setting the shutdown temperature to less than or equal to the end derating temperature or unchecking the shutdown option will turn off the shutdown function, neither shutdown.

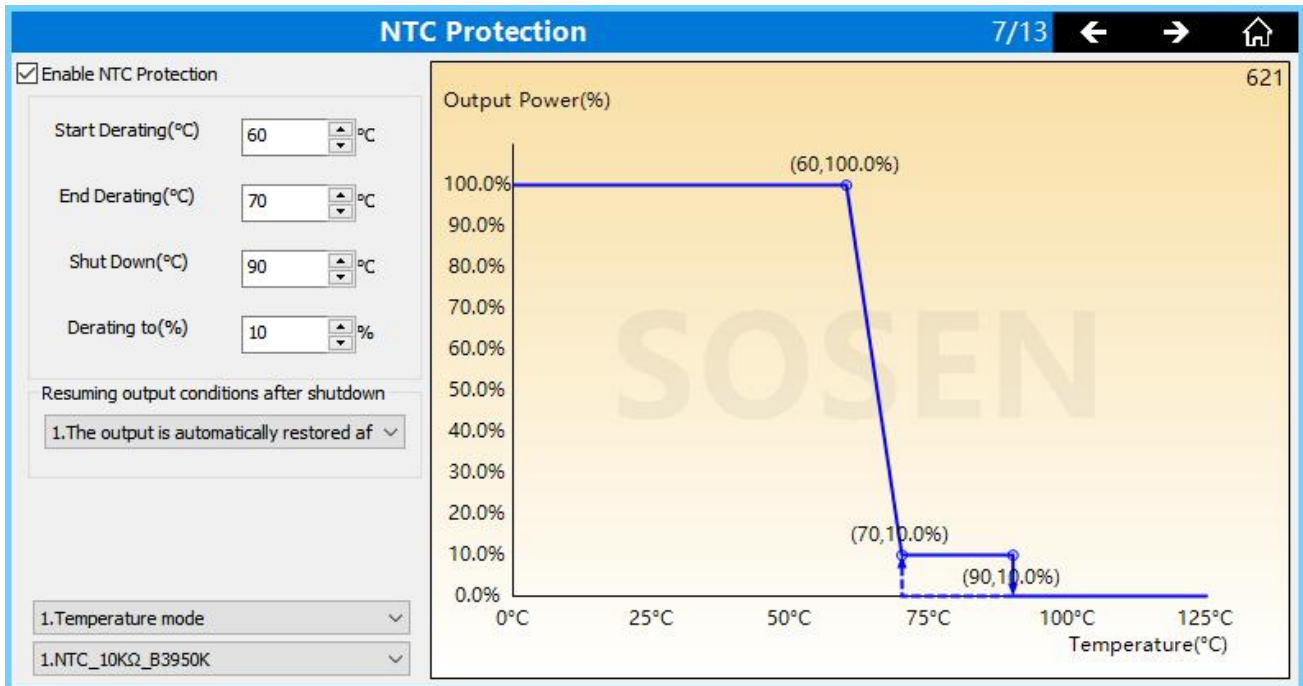

Figure 1

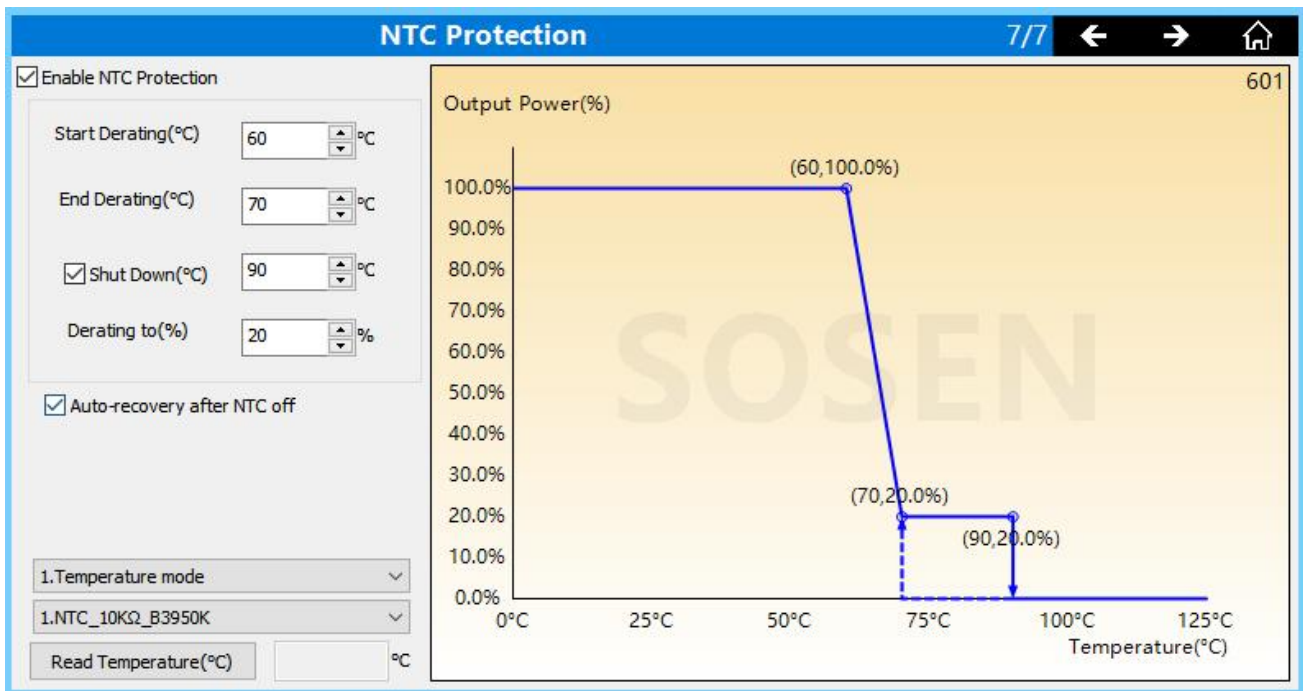

Figure 2

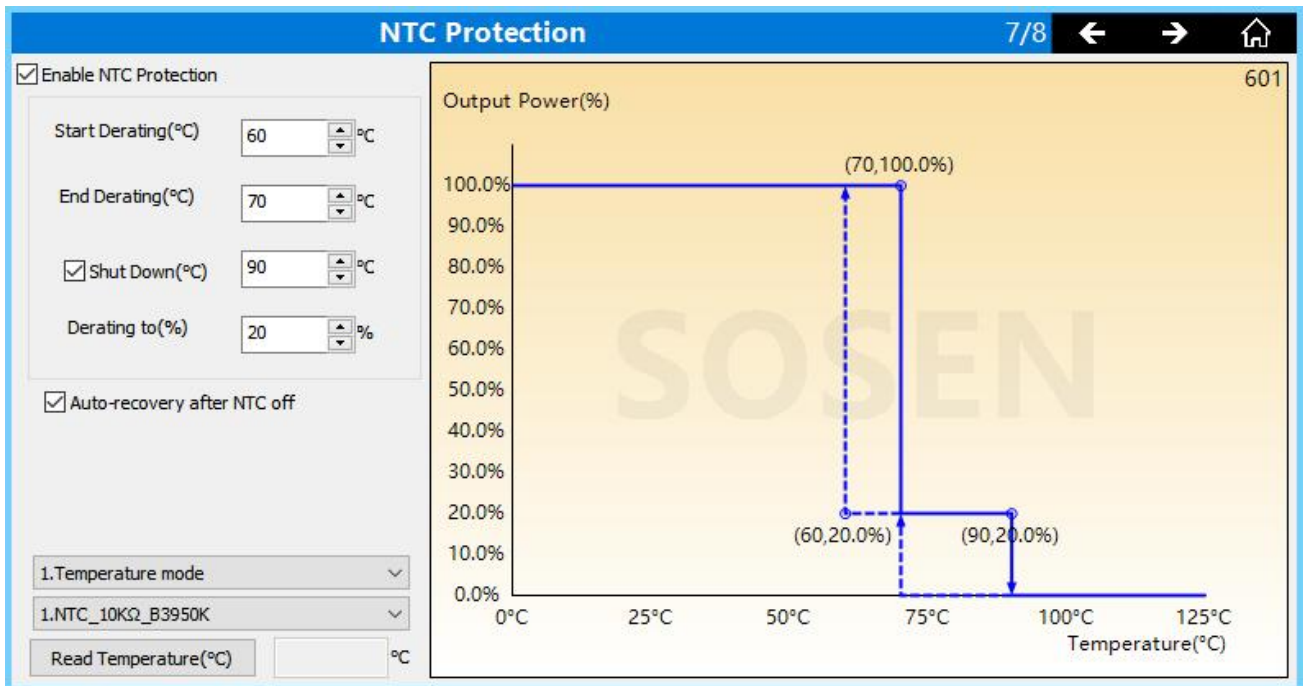

Figure 3

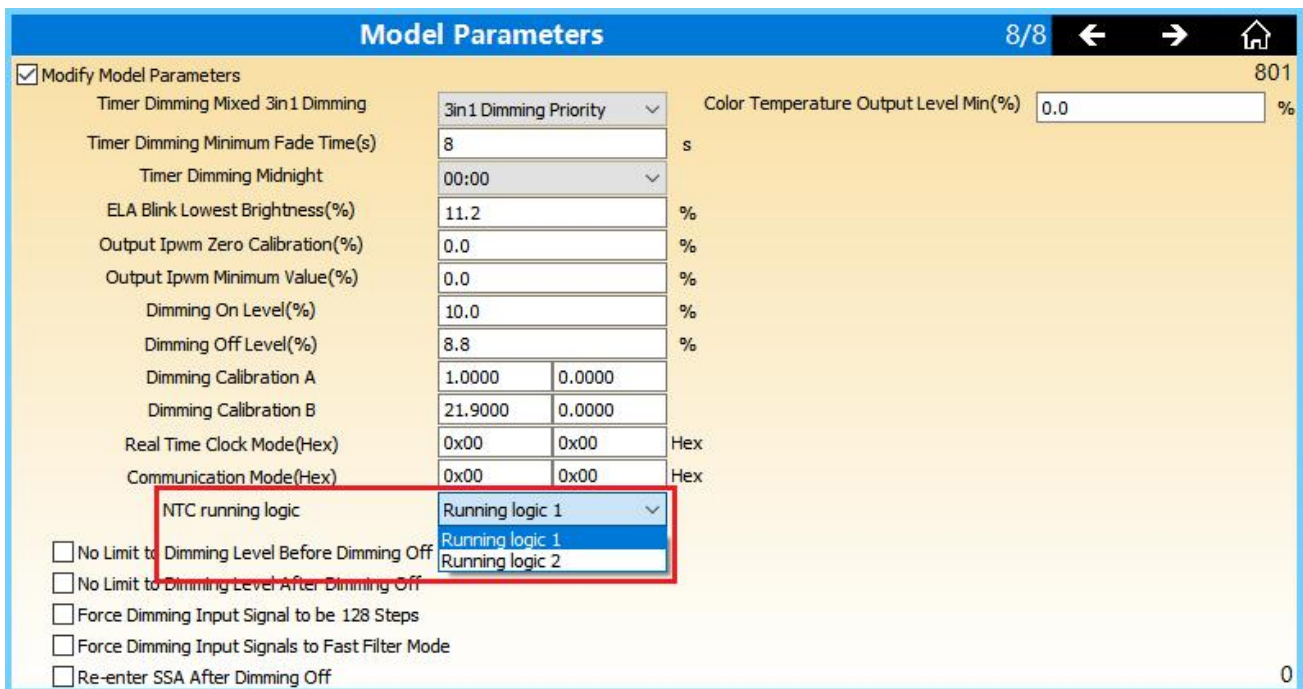

Figure 4

A thermistor "temperature-resistance" mapping table is attached.

10KΩ_B3950K	10KΩ_B3435K	10KΩ_B3380K
Temperature Resistance	Temperature Resistance	Temperature Resistance



Shenzhen SOSEN Electronics Co Ltd
Building A,Block 1,Pengzhanhui No.233 Zhongxin Road,Xinqiao Community Xinqiao
street, Bao'an District Shenzhen 518125, China

°C	KΩ	°C	KΩ	°C	KΩ
0	32.7547	0	27.4936	0	27.2186
1	31.1243	1	26.3245	1	26.076
2	29.5847	2	25.2119	2	24.9877
3	28.1301	3	24.1527	3	23.9509
4	26.7556	4	23.1442	4	22.9629
5	25.4562	5	22.1835	5	22.0211
6	24.2274	6	21.2682	6	21.123
7	23.065	7	20.3959	7	20.2666
8	21.965	8	19.5644	8	19.4495
9	20.9239	9	18.7714	9	18.6698
10	19.938	10	18.0151	10	17.9255
11	19.0041	11	17.2935	11	17.2139
12	18.1193	12	16.6048	12	16.5344
13	17.2807	13	15.9475	13	15.8856
14	16.4857	14	15.3198	14	15.2658
15	15.7317	15	14.7203	15	14.6735
16	15.0164	16	14.1475	16	14.1075
17	14.3376	17	13.6003	17	13.5664
18	13.6933	18	13.0772	18	13.0489
19	13.0816	19	12.5771	19	12.554
20	12.5005	20	12.0988	20	12.0805
21	11.9485	21	11.6413	21	11.6281
22	11.4239	22	11.2037	22	11.1947
23	10.9252	23	10.7848	23	10.7795
24	10.451	24	10.3839	24	10.3815
25	10	25	10	25	10
26	9.5709	26	9.6324	26	9.6342
27	9.1626	27	9.2802	27	9.2835
28	8.7738	28	8.9428	28	8.947
29	8.4037	29	8.6195	29	8.6242
30	8.0512	30	8.3096	30	8.3145
31	7.7154	31	8.0124	31	8.0181
32	7.3953	32	7.7275	32	7.7337
33	7.0903	33	7.4541	33	7.4609
34	6.7995	34	7.1919	34	7.1991
35	6.5221	35	6.9403	35	6.9479
36	6.2576	36	6.6987	36	6.7067
37	6.0051	37	6.4669	37	6.4751
38	5.7642	38	6.2442	38	6.2526
39	5.5342	39	6.0304	39	6.039
40	5.3146	40	5.825	40	5.8336
41	5.1049	41	5.6276	41	5.6357



Shenzhen SOSEN Electronics Co Ltd
Building A,Block 1,Pengzhanhui No.233 Zhongxin Road,Xinqiao Community Xinqiao
street, Bao'an District Shenzhen 518125, China

42	4.9045	42	5.438	42	5.4454
43	4.713	43	5.2557	43	5.2623
44	4.53	44	5.0804	44	5.0863
45	4.3551	45	4.9119	45	4.9169
46	4.1878	46	4.7498	46	4.7539
47	4.0278	47	4.5939	47	4.5971
48	3.8748	48	4.4439	48	4.4461
49	3.7283	49	4.2995	49	4.3008
50	3.5882	50	4.1605	50	4.1609
51	3.454	51	4.0268	51	4.0262
52	3.3255	52	3.898	52	3.8964
53	3.2025	53	3.7739	53	3.7714
54	3.0846	54	3.6544	54	3.651
55	2.9717	55	3.5393	55	3.535
56	2.8635	56	3.4284	56	3.4231
57	2.7597	57	3.3215	57	3.3152
58	2.6603	58	3.2185	58	3.2113
59	2.5649	59	3.1191	59	3.111
60	2.4734	60	3.0234	60	3.0143
61	2.3856	61	2.931	61	2.9224
62	2.3014	62	2.8419	62	2.8337
63	2.2206	63	2.7559	63	2.7482
64	2.1431	64	2.6729	64	2.6657
65	2.0686	65	2.5929	65	2.5861
66	1.997	66	2.5156	66	2.5093
67	1.9283	67	2.441	67	2.4351
68	1.8623	68	2.369	68	2.3635
69	1.7989	69	2.2994	69	2.2943
70	1.738	70	2.2322	70	2.2275
71	1.6794	71	2.1673	71	2.1627
72	1.6231	72	2.1046	72	2.1001
73	1.5689	73	2.044	73	2.0396
74	1.5168	74	1.9854	74	1.9811
75	1.4667	75	1.9288	75	1.9245
76	1.4185	76	1.874	76	1.8698
77	1.3722	77	1.8211	77	1.817
78	1.3275	78	1.7699	78	1.7658
79	1.2845	79	1.7204	79	1.7164
80	1.2431	80	1.6725	80	1.6685
81	1.2033	81	1.6262	81	1.6224
82	1.1649	82	1.5813	82	1.5777
83	1.1279	83	1.5379	83	1.5345
84	1.0923	84	1.4959	84	1.4927



Shenzhen SOSEN Electronics Co Ltd
Building A,Block 1,Pengzhanhui No.233 Zhongxin Road,Xinqiao Community Xinqiao
street, Bao'an District Shenzhen 518125, China

85	1.058	85	1.4553	85	1.4521
86	1.0249	86	1.4159	86	1.4129
87	0.993	87	1.3778	87	1.3749
88	0.9623	88	1.3408	88	1.3381
89	0.9326	89	1.3051	89	1.3025
90	0.904	90	1.2704	90	1.268
91	0.8764	91	1.2368	91	1.2343
92	0.8498	92	1.2043	92	1.2016
93	0.8241	93	1.1728	93	1.17
94	0.7994	94	1.1422	94	1.1393
95	0.7754	95	1.1126	95	1.1096
96	0.7523	96	1.0839	96	1.0807
97	0.73	97	1.056	97	1.0528
98	0.7085	98	1.029	98	1.0256
99	0.6877	99	1.0028	99	0.9993
100	0.6676	100	0.9774	100	0.9738
101	0.6482	101	0.9527	101	0.9492
102	0.6295	102	0.9288	102	0.9254
103	0.6113	103	0.9055	103	0.9022
104	0.5938	104	0.883	104	0.8798
105	0.5769	105	0.8611	105	0.858
106	0.5605	106	0.8399	106	0.8368
107	0.5447	107	0.8193	107	0.8162
108	0.5293	108	0.7992	108	0.7963
109	0.5145	109	0.7798	109	0.7769
110	0.5002	110	0.7609	110	0.758
111	0.4863	111	0.7425	111	0.7397
112	0.4729	112	0.7247	112	0.7219
113	0.4599	113	0.7074	113	0.7046
114	0.4474	114	0.6906	114	0.6878
115	0.4352	115	0.6742	115	0.6715
116	0.4234	116	0.6583	116	0.6556
117	0.412	117	0.6429	117	0.6402
118	0.4009	118	0.6278	118	0.6252
119	0.3902	119	0.6132	119	0.6106
120	0.3799	120	0.599	120	0.5964
				121	0.5826
				122	0.5692
				123	0.5562
				124	0.5435
				125	0.5311



5.2.8.OTP Protection

There is a temperature sensor inside the LED driver that detects the internal temperature of the LED driver. The internal temperature protection point of the LED driver can be set via the programming interface.

Note: The LED driver hardware must support OTP functionality.

DALI power supply OTP operation logic: When the temperature is lower than 90 ° C, the output power is 100%;When the temperature is greater than 95 ° C and less than 75 ° C, the output power runs in an oblique line between 90 ° C and 95 ° C, with the increase and decrease of the temperature, the output power will be accompanied by this decrease and increase;When the temperature is greater than 95°C, the output power will be reduced to 20% and maintained at 20%;When the temperature is greater than 100 ° C, the output will be turned off.In addition, set the off temperature to be less than or equal to the temperature at which the derating ends. This disables the off function.

After OTP is disabled, output can be resumed according to three different recovery conditions.The first condition is to resume output when the temperature drops to the end derating temperature.The second condition is to restore the output when the LED driver is powered back on.The third condition is to restore power after reprogramming the LED driver.The output power level specified at the end of derating will be restored.

DALI Power OTP user interface is as follows:

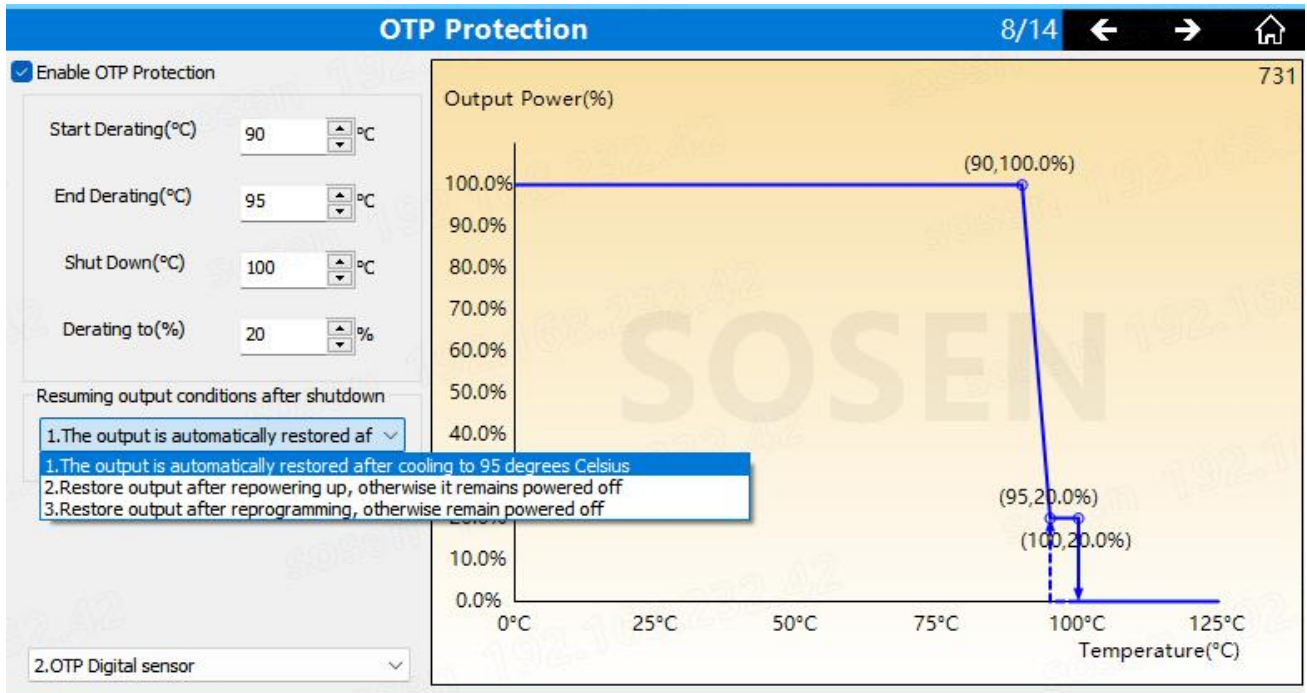

The 3-in-1 power supply runs the same logic as DALI. The difference is that the 3-in-1 power supply can only choose whether the OTP is automatically restored after shutdown, and the current temperature can be read in the user interface, as shown below:

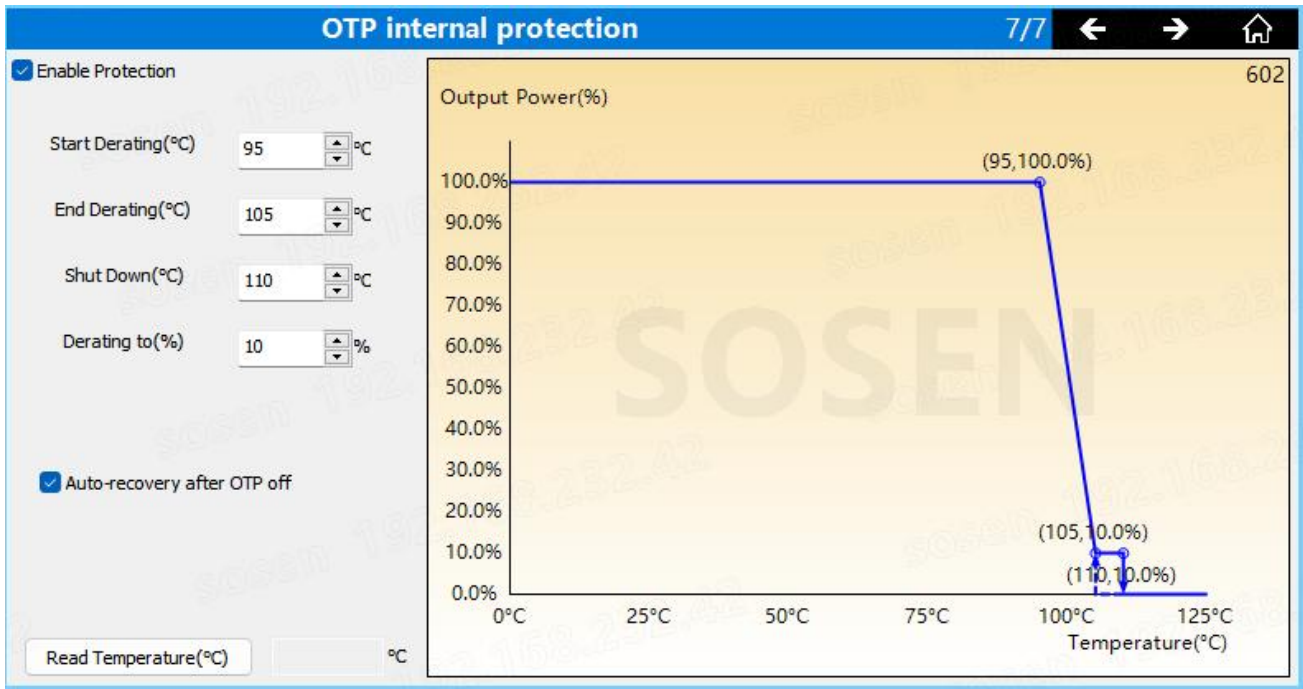

5.2.9. Model Parameters

The model parameters page can set the dimming on voltage and dimming off voltage of the LED driver, as well as other parameters (the setting of the dimming on voltage and dimming off voltage requires hardware support).

The DALI power model feature parameter interface is as follows:

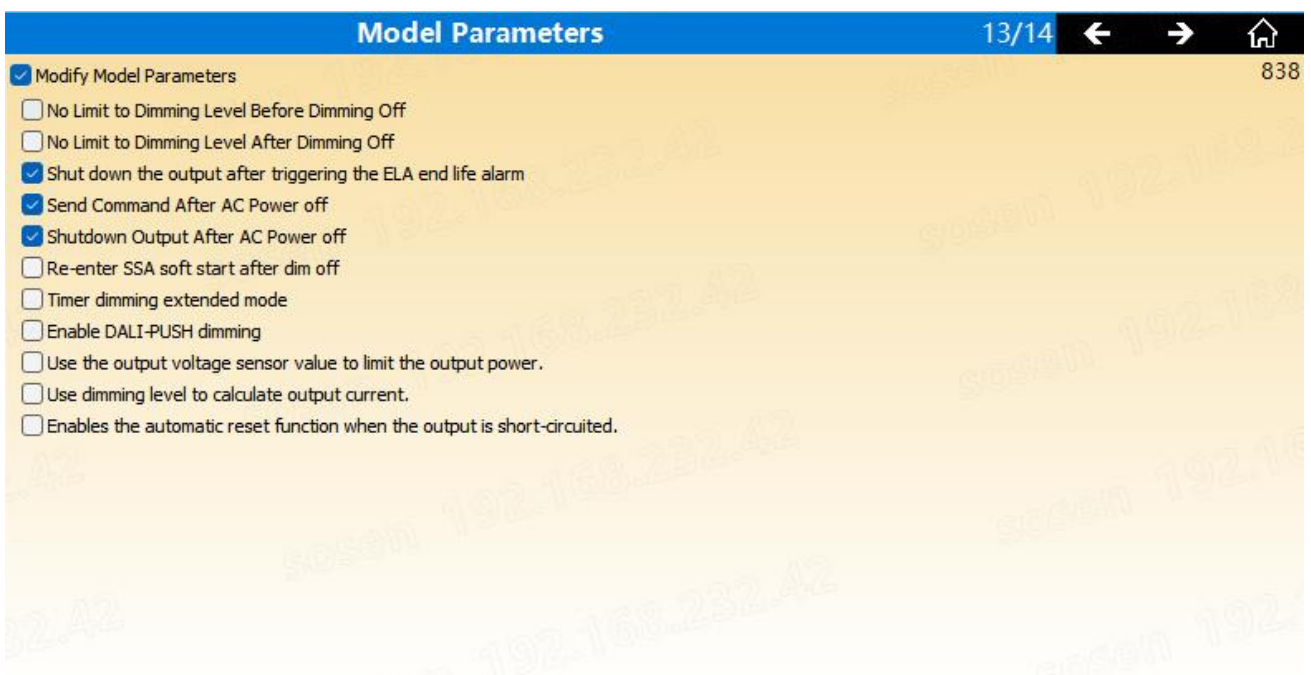



Model Parameters 14/14

Modify Model Parameters 839

Output Ipwm Zero Calibration(Hex)	38,73,E6	Hex	Output Rated Power(W)	110	W
Output Ipwm Span Calibration(%)	0.0	%	Channels	1	
Output Ipwm Limit Minimum(%)	1.0	%	Empty Load Voltage Raise Mode(Hex)	0x5F	Hex
Dimming On Level(%)	1.6	%	Empty Load Voltage Range(Hex)	0x21	Hex
Dimming Off Level(%)	0.8	%	Reference Voltage Delay Time(ms)	504	ms
Fast Startup Mode(Hex)	0x00	Hex	Reference Current Delay Time(ms)	504	ms
Lowtemperature Startup Mode(Hex)	0x00	Hex	Reference Voltage Fade Time(ms)	0	ms
ACI Sensor Calibration(Hex)	8B,00	Hex	Reference Current Fade Time(ms)	8	ms
ADC Work Mode(Hex)	0x03	Hex	Vref Polarity Frequency(Hex)	0x00	Hex
ACI Work Mode(Hex)	0x00	Hex	Iref Polarity Frequency(Hex)	0x00	Hex
SSA Work Mode(Hex)	0x00	Hex	Output voltage sensor calibration(Hex)	0xF6	Hex
ELA Work Mode(Hex)	0x00	Hex	Output current sensor calibration(Hex)	0xEC	Hex
CLO Work Mode(Hex)	0x00	Hex	OTP sensor calibration(Hex)	00,00	Hex
TIM Work Mode(Hex)	0x00	Hex	NTC sensor calibration(Hex)	00,00	Hex
OTP Work Mode(Hex)	0x00	Hex	Model Parameters(Hex)	00,00	Hex
NTC Work Mode(Hex)	0x00	Hex	Reduce Voltage After Dim Off	No Reduce	▼

The three-in-one power model feature parameter interface is as follows:

Model Parameters 8/8

Modify Model Parameters 801

Timer Dimming Mixed 3in1 Dimming	3in1 Dimming Priority	▼	Color Temperature Output Level Min(%)	0.0	%
Timer Dimming Minimum Fade Time(s)	8	s	Output Ipwm Midpoint Calibration(%)	0.0	%
Timer Dimming Midnight	00:00	▼			
ELA Blink Lowest Brightness(%)	11.2	%			
Output Ipwm Zero Calibration(%)	0.0	%			
Output Ipwm Minimum Value(%)	0.0	%			
Dimming On Level(%)	10.0	%			
Dimming Off Level(%)	8.8	%			
Dimming Calibration A	1.0000	0.0000			
Dimming Calibration B	21.9000	0.0000			
Real Time Clock Mode(Hex)	0x00	0x00	Hex		
Communication Mode(Hex)	0x00	0x00	Hex		
NTC running logic	Running logic 1	▼			

- No Limit to Dimming Level Before Dimming Off
- No Limit to Dimming Level After Dimming Off
- Force Dimming Input Signal to be 128 Steps
- Force Dimming Input Signals to Fast Filter Mode
- Re-enter SSA After Dimming Off

5.2.10.DALI Application Parameters

On this page, you can set the DALI application parameters of the LED driver, including configuration parameters, address parameters, scene parameters and group parameters (when setting parameters, you need to tick the corresponding box).DALI application parameters are available only for DALI power supply, as shown below:

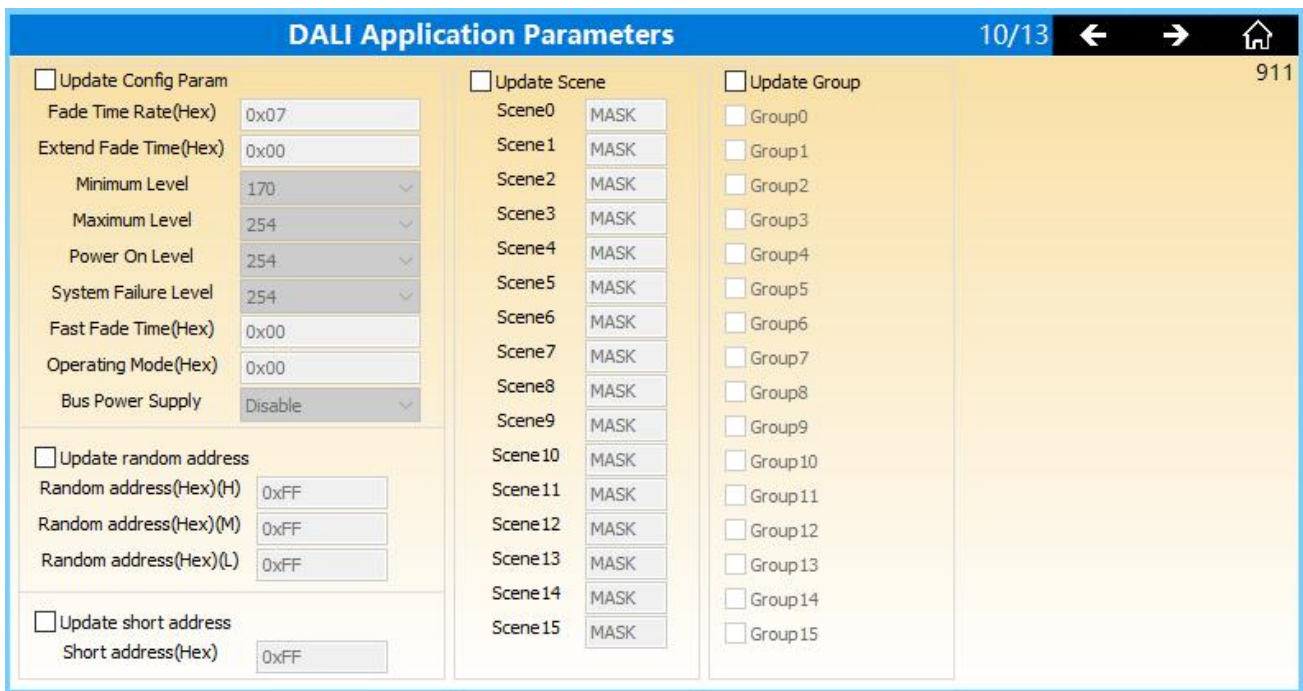

DALI Application Parameters		10/13	←	→	🏠	911
<input type="checkbox"/> Update Config Param						
Fade Time Rate(Hex)	0x07					
Extend Fade Time(Hex)	0x00					
Minimum Level	170					
Maximum Level	254					
Power On Level	254					
System Failure Level	254					
Fast Fade Time(Hex)	0x00					
Operating Mode(Hex)	0x00					
Bus Power Supply	Disable					
<input type="checkbox"/> Update random address						
Random address(Hex)(H)	0xFF					
Random address(Hex)(M)	0xFF					
Random address(Hex)(L)	0xFF					
<input type="checkbox"/> Update short address						
Short address(Hex)	0xFF					
<input type="checkbox"/> Update Scene						
Scene0	MASK					
Scene1	MASK					
Scene2	MASK					
Scene3	MASK					
Scene4	MASK					
Scene5	MASK					
Scene6	MASK					
Scene7	MASK					
Scene8	MASK					
Scene9	MASK					
Scene10	MASK					
Scene11	MASK					
Scene12	MASK					
Scene13	MASK					
Scene14	MASK					
Scene15	MASK					
<input type="checkbox"/> Update Group						
<input type="checkbox"/> Group0						
<input type="checkbox"/> Group1						
<input type="checkbox"/> Group2						
<input type="checkbox"/> Group3						
<input type="checkbox"/> Group4						
<input type="checkbox"/> Group5						
<input type="checkbox"/> Group6						
<input type="checkbox"/> Group7						
<input type="checkbox"/> Group8						
<input type="checkbox"/> Group9						
<input type="checkbox"/> Group10						
<input type="checkbox"/> Group11						
<input type="checkbox"/> Group12						
<input type="checkbox"/> Group13						
<input type="checkbox"/> Group14						
<input type="checkbox"/> Group15						

5.2.11.Product Identification

The product identification parameters of the LED driver can be displayed on this page, which cannot be changed.Product identification is only available for DALI models, as shown below:

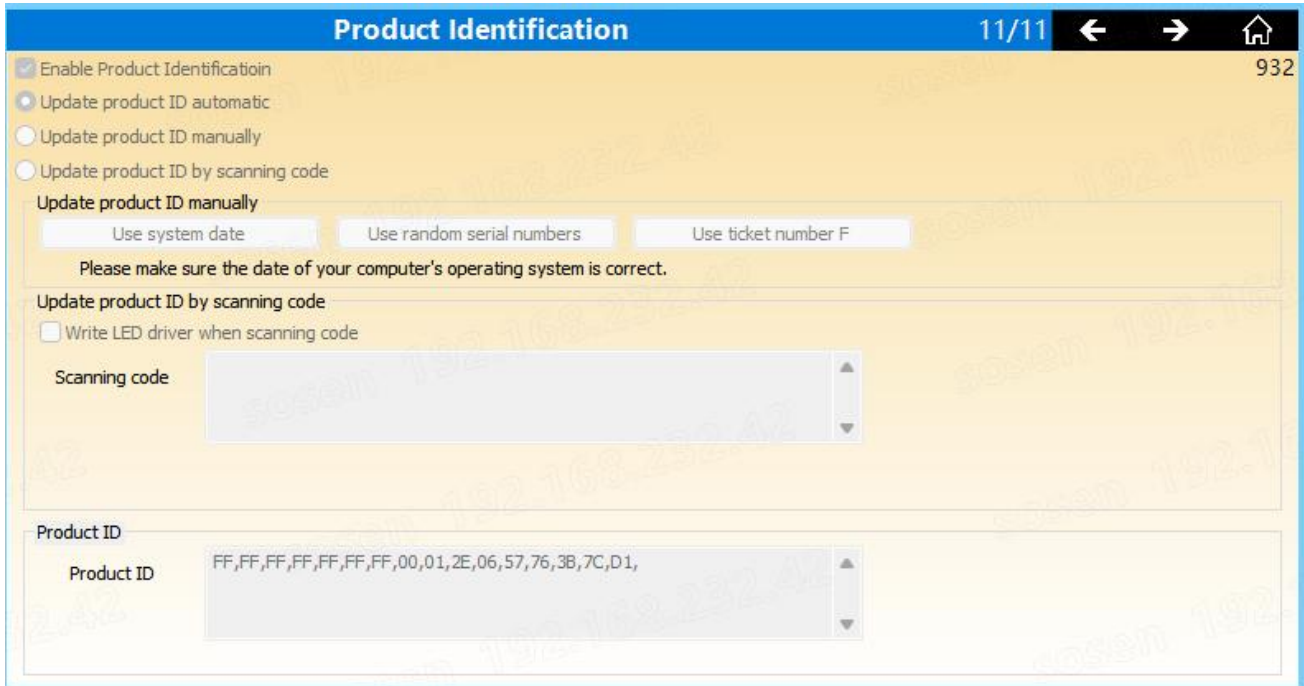

The screenshot shows a web interface titled "Product Identification" with a page number "11/11" and navigation icons. The interface includes several sections:

- Enable Product Identification:** A checked checkbox.
- Update product ID options:** Radio buttons for "Update product ID automatic" (selected), "Update product ID manually", and "Update product ID by scanning code".
- Update product ID manually:** Three buttons: "Use system date", "Use random serial numbers", and "Use ticket number F". Below these is a note: "Please make sure the date of your computer's operating system is correct."
- Update product ID by scanning code:** A checkbox for "Write LED driver when scanning code" (unchecked) and a "Scanning code" input field.
- Product ID:** A "Product ID" input field containing the hexadecimal string: "FF,FF,FF,FF,FF,FF,FF,00,01,2E,06,57,76,3B,7C,D1".

5.2.12.DALI Memory Bank 1

On this page, you can set the relevant parameters of DALI Memory Bank 1 (when setting relevant parameters, you need to tick the relevant parameters).

DALI storage blocks are available only for DALI models, as shown in the following figure:

DALI Memory Bank 1
13/13
← → 🏠

914

<input type="checkbox"/> Luminaire manufacturer GTIN	<input type="text" value="281474976710655"/>	
<input type="checkbox"/> Luminaire identification number(Hex)	<input type="text" value="FFFFFFFFFFFFFF"/>	Hex
<input type="checkbox"/> Content Format(Hex)	<input type="text" value="0003"/>	Hex
<input type="checkbox"/> Luminaire year of manufacture(0~99)	<input type="text" value="255"/>	
<input type="checkbox"/> Luminaire week of manufacture(1~53)	<input type="text" value="255"/>	
<input type="checkbox"/> Nominal input power(W)	<input type="text" value="65535"/>	W
<input type="checkbox"/> Power at min dim level(W)	<input type="text" value="65535"/>	W
<input type="checkbox"/> Nominal min AC input voltage(90~480V)	<input type="text" value="65535"/>	V
<input type="checkbox"/> Nominal max AC input voltage(90~480V)	<input type="text" value="65535"/>	V
<input type="checkbox"/> Nominal light output	<input type="text" value="16777215"/>	
<input type="checkbox"/> Color rendering index CRI(0~100)	<input type="text" value="255"/>	
<input type="checkbox"/> Correlated color temperature CCT	<input type="text" value="65535"/>	
<input type="checkbox"/> Light distribution type	<input type="text" value="255"/>	
<input type="checkbox"/> Luminaire description	<input type="text"/>	
<input type="checkbox"/> Luminaire name	<input type="text"/>	

5.2.13.DALI Dimming

This user interface cannot be used for DALI dimming control, but is only used to modify DALI dimming parameters, such as minimum brightness level, power-on brightness level, update address, scene, etc., with the DALI master and the corresponding software, the parameters set on this page can be read in the master software. On the right side of the interface, set the power switch status of the internal integrated bus.

DALI dimming only DALI power supply, as shown below:

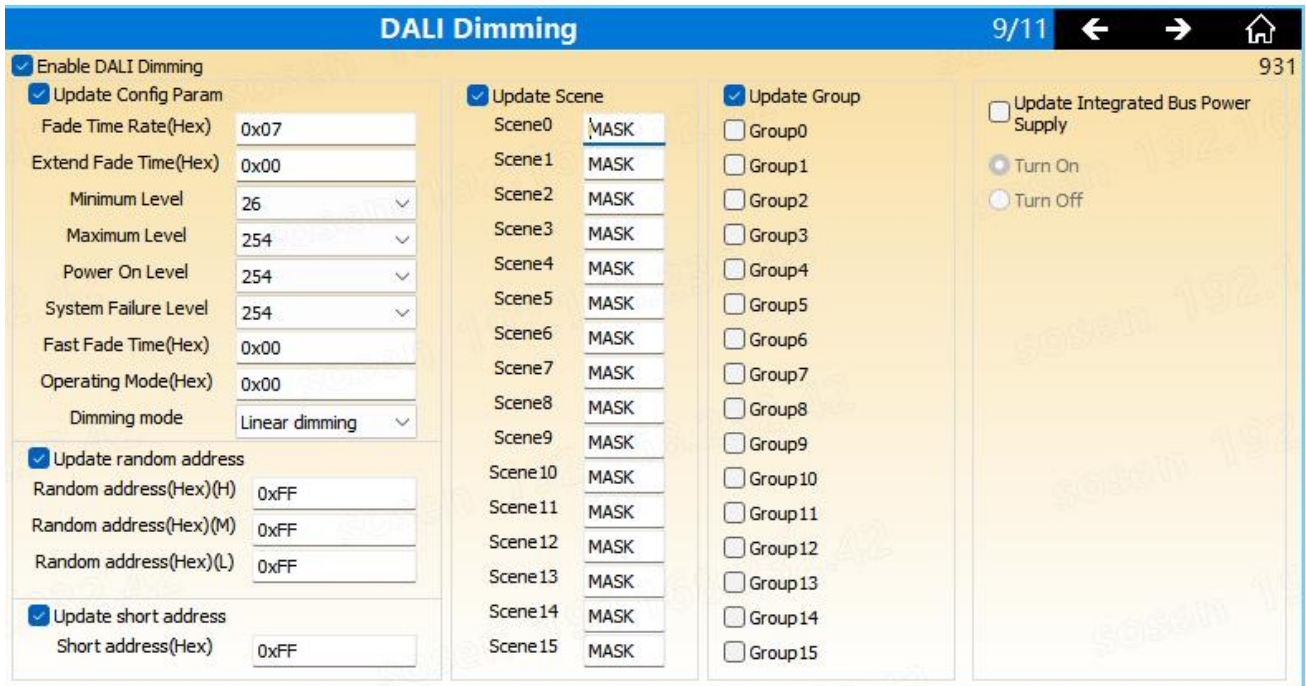

5.2.14.ACI Dimming

The LED driver has an under-voltage protection function, that is, ACI dimming, this interface can set the dimming voltage value of the protection starting point (point B), the dimming voltage value of the protection end point (point A), and the dimming level.

ACI dimming function only DALI model power supply, as shown below:

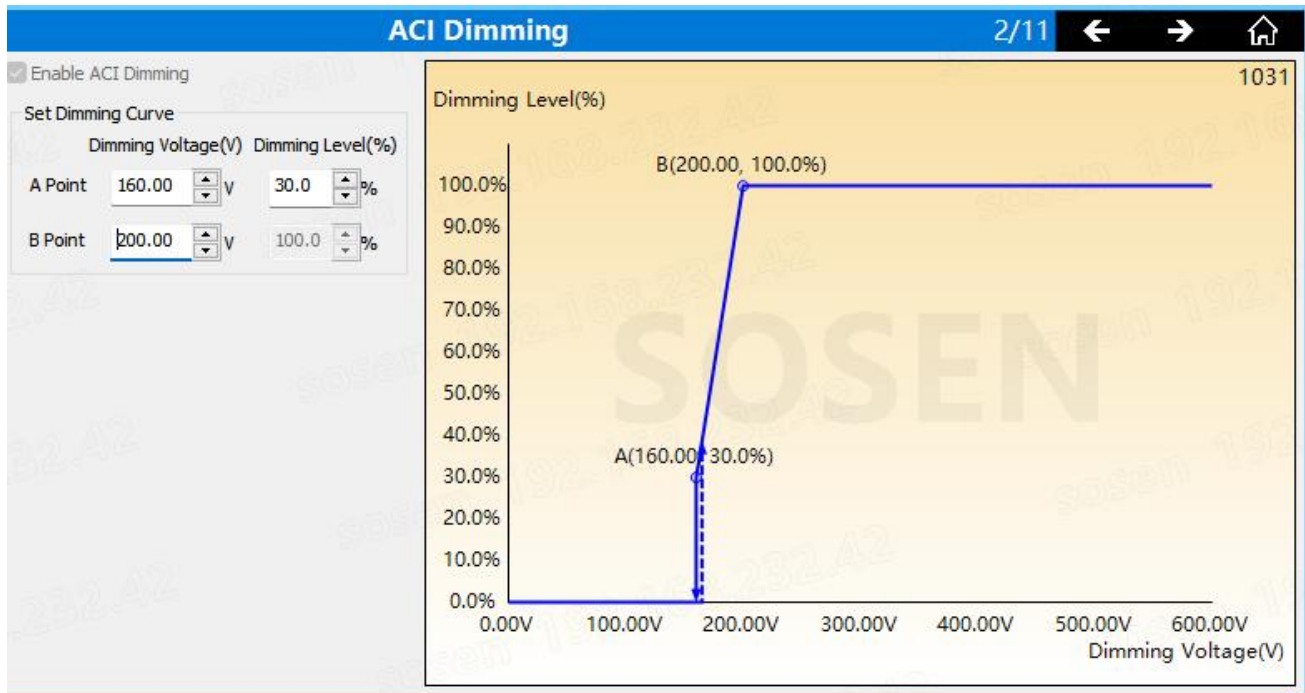

5.2.15.Switch Dimming

DALI power supply with SWT eight-speed dimming function LED driver has four lines, respectively black, white, red, yellow lines. In the following table, the selected lines are connected together to output corresponding dimming levels.

Dimming grade	black	white	red	yellow
1	√	√	√	√
2	√	√	√	×
3	√	√	×	√
4	√	√	×	×
5	√	×	√	√
6	√	×	√	×
7	√	×	×	√
8	√	×	×	×

DALI power SWT user interface can set the corresponding dimming level of the gear, as shown below:

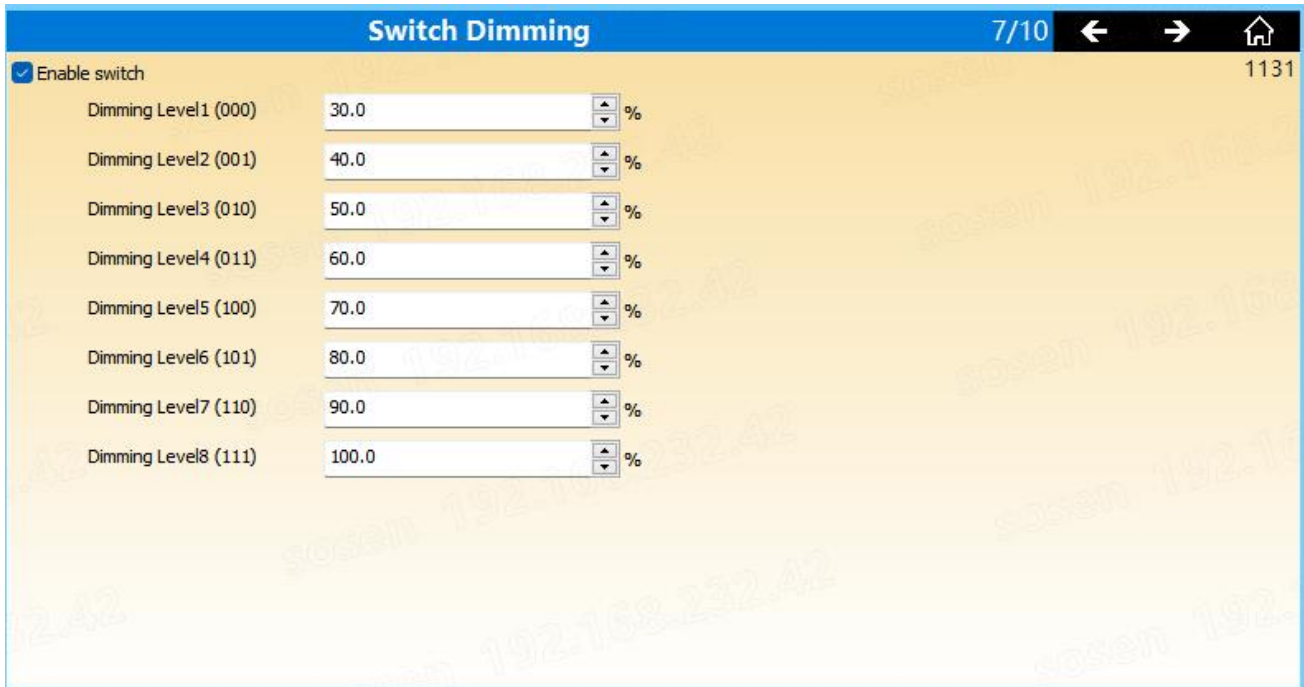

Three-in-one power supply SWT function is five-speed dimming, the following table is the dial gear resistance and the corresponding segment output parameter requirements:

	Resistance Range	Output Level	Software Setting Status
First Segment Output	0kΩ~15kΩ	50%	Output level can be set
Second Segment Output	15kΩ~29.5kΩ	60%	Output level can be set
Third Segment Output	29.5kΩ~60.5kΩ	70%	Output level can be set
Fourth Segment Output	60.5kΩ~	80%	Output level can be set
Fifth Segment Output	Open-circuit	100%	Not adjustable

Three-in-one power supply SWT can set the resistance of the corresponding gear as well as the upper bias resistance and the lower bias resistance, but it is generally fixed because of the hardware circuit restrictions.As shown below:

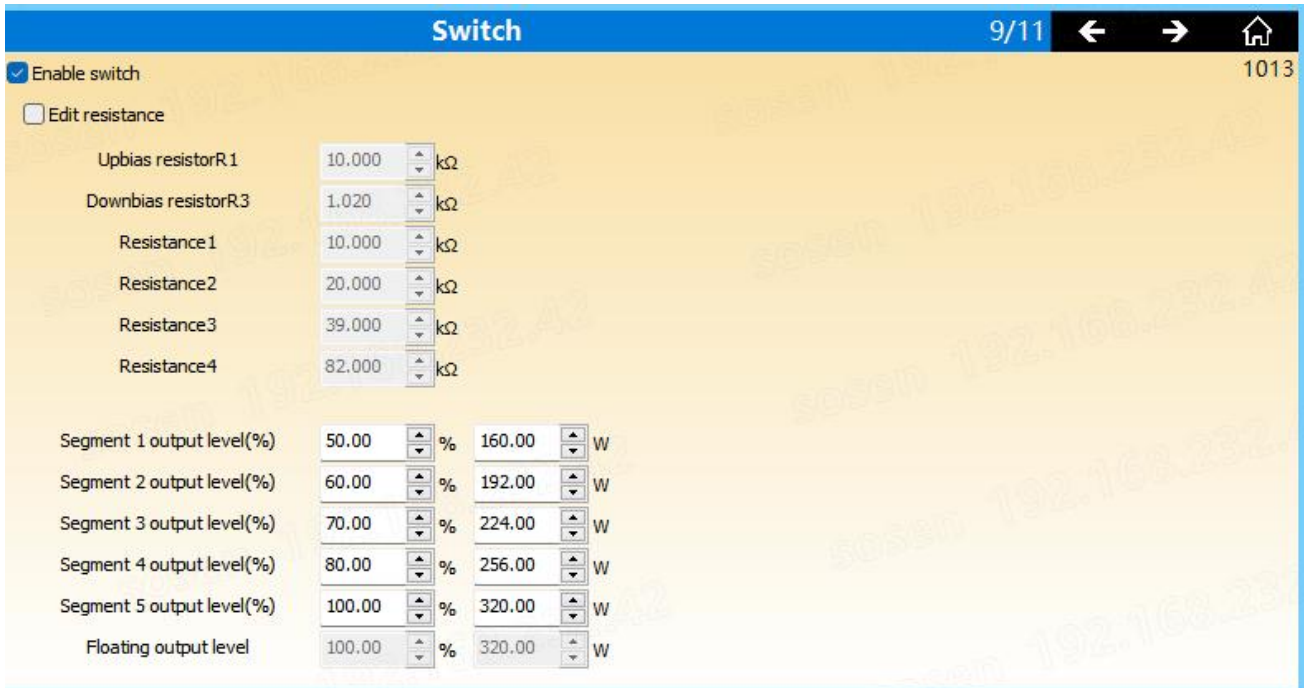

5.2.16. Conversion Efficiency

This user interface is a correction value for the D4i power parameter for power calibration.

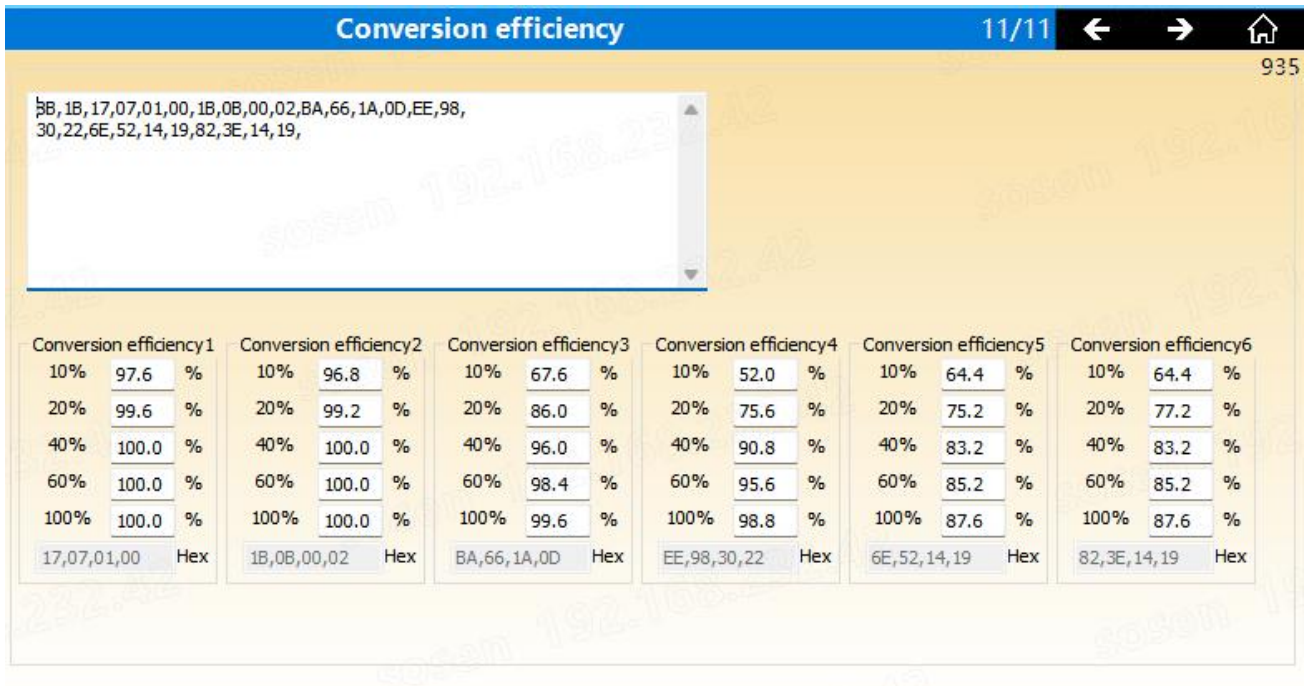

5.3.Introduction to the adaptive timer function

5.3.1.Adaptive timer function application

SOSEN's adaptive timer function takes into account the use of lamps and lanterns in different regions and different seasons. The LED driver automatically calculates the runtime in a "self-learning" manner, corresponding to the timer dimming curve set at the time of initial installation, to achieve adaptive timing dimming function. The timer dimming curve only needs to be set once before installation. SOSEN's adaptive timer dimming function consists of 2 modes: "Self-Adapt-Midnight Timer" and "Self-Adapt-Percentage Timer".

5.3.2.Adaptive time calculation

(1) Manually switch on and off the machine at least once a day

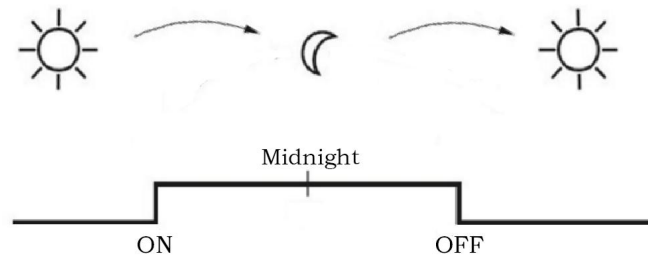

(2) The effective run time is calculated automatically

- a. The power-on running time is not less than 2 hours, and it is recorded as 1 effective running time.
- b. The LED driver power-down time is not less than 1s, which will be recorded as a new time.
- c. The last effective running time, the difference between the absolute value of the effective running time before and not more than 1 hour, is valid calculation data. Three in one power supply 4 times effective calculation data, obtained "Average On Hours" (referred to as AOH), that is, "adaptive cycle". DALI power supply 2 effective time calculation AOH.

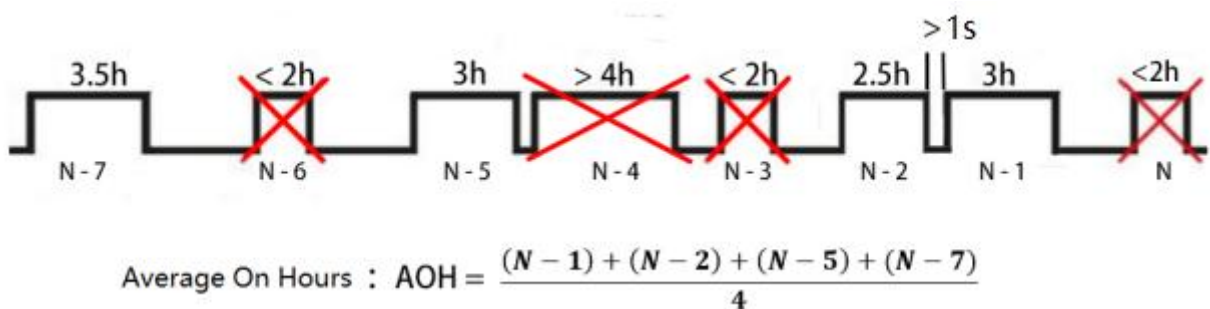

5.3.3.Adaptive timer dimming

(1) Self-Adapt-Midnight Timer

- a. The 3-in-1 power supply uses the start point set in section 4 of the dimming curve

as the adaptive midpoint.The DALI power supply is set at the The 00:00 point on the X-axis as the adaptive midpoint.

b. Then according to "Average On Hours" (AOH), it corresponds to both sides of midnight. The red line is the change in power output when the LED driver is running.

DALI electrical source ADAPTS midpoint dimming user interface as follows:

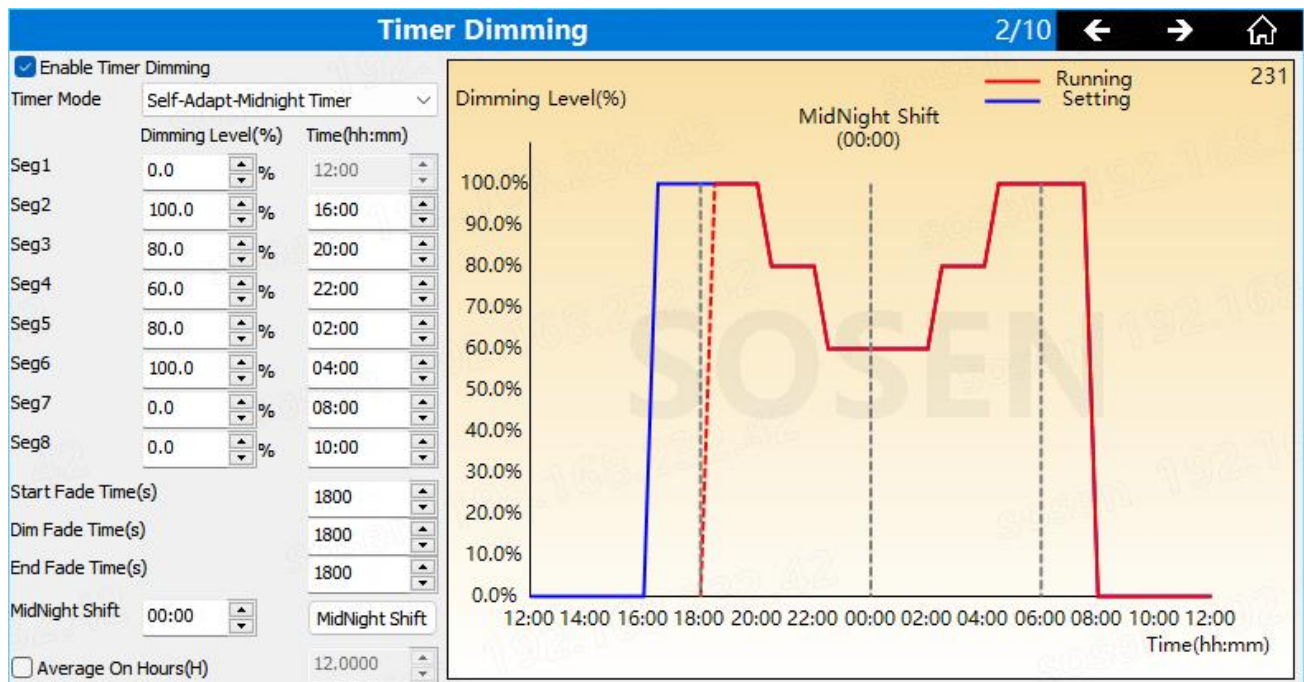

3-in-1 power source ADAPTS midpoint dimming user interface as follows:

(2) Self-Adapt-Percentage Timer

According to the percentage ratio of "Average On Hours" (AOH), the time of setting the curve is converted proportionally to obtain the LED driver running output change curve

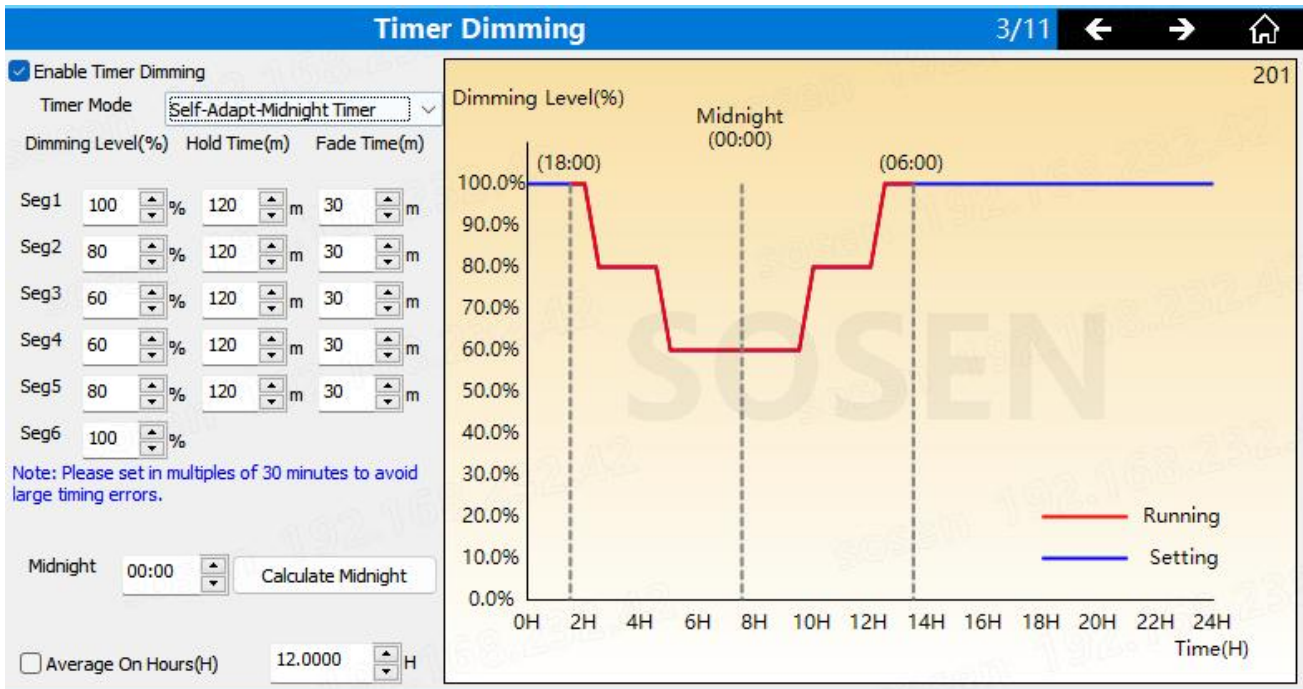

DALI electrical source adaptive percentage dimming user interface is as follows:

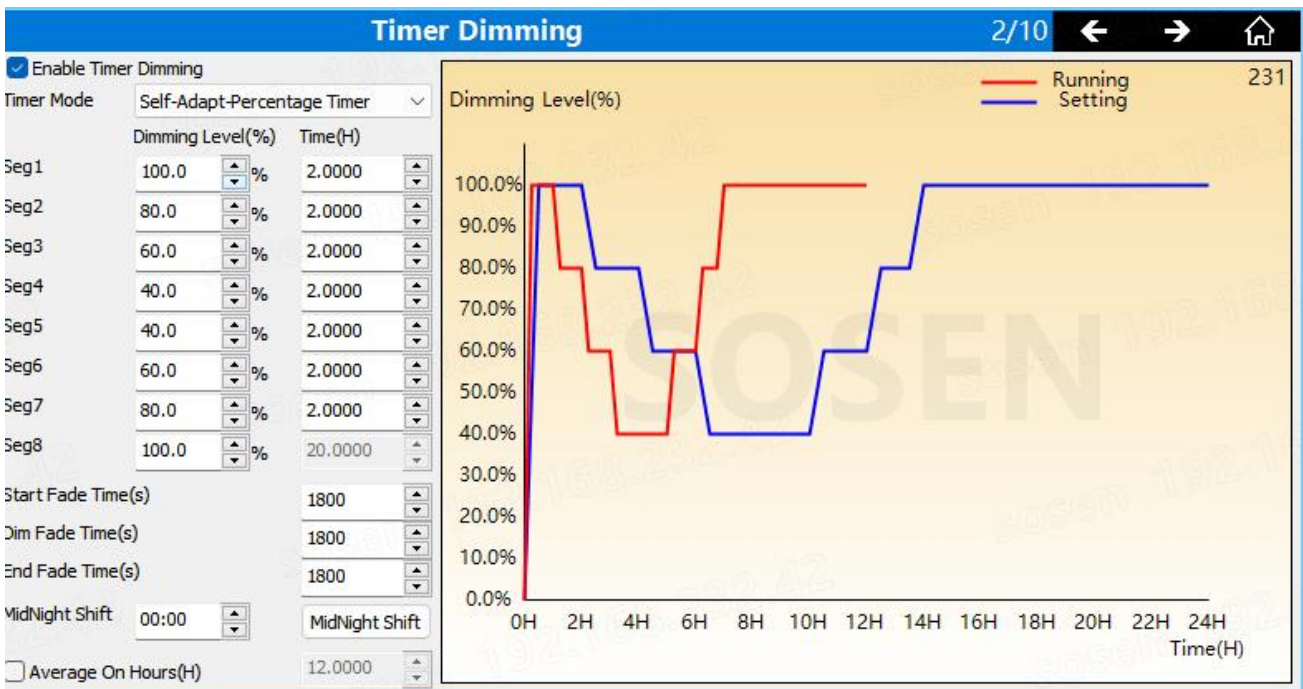

The 3-in-1 electrical dimming user interface is derived from adaptive percentage dimming as follows:

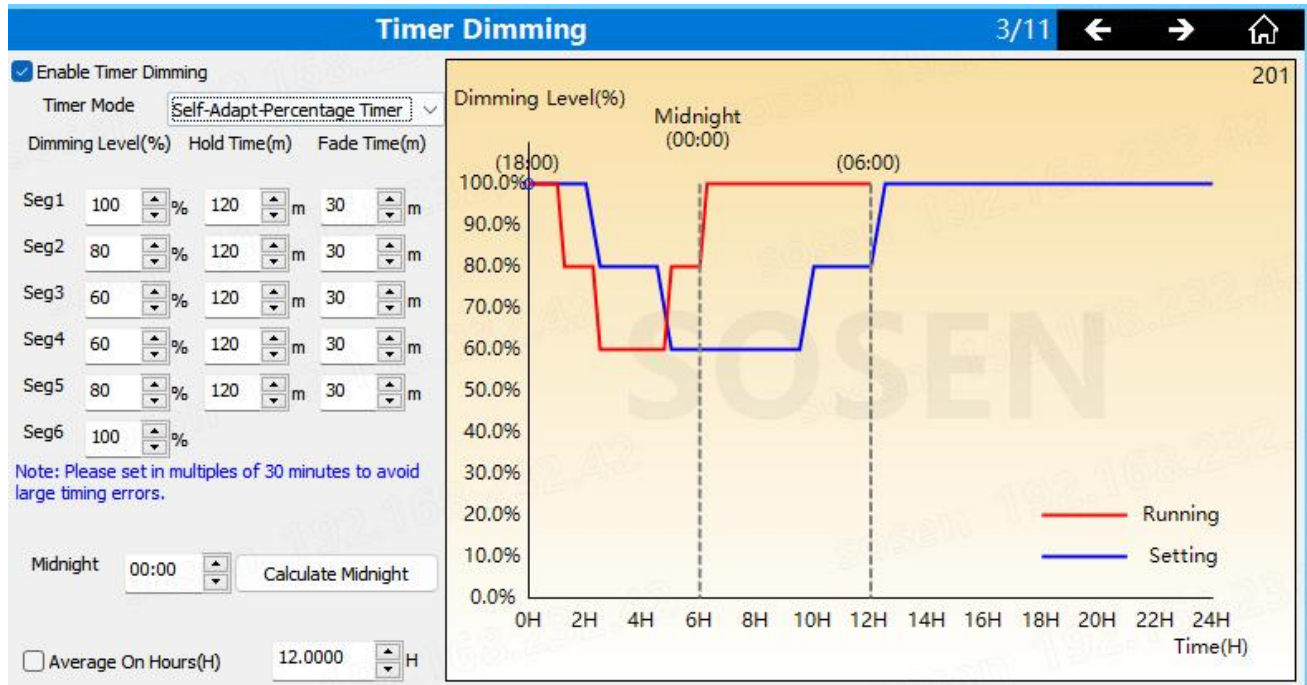

Versions	Date	Description
V1.00	2022/02/11	Initial release
V1.01	2022/04/11	Fixed some page display



Shenzhen SOSEN Electronics Co Ltd
Building A,Block 1,Pengzhanhui No.233 Zhongxin Road,Xinqiao Community Xinqiao
street, Bao'an District Shenzhen 518125, China

V1.1	2022/10/13	Add some features
V1.2	2023/04/25	Added new communication methods for models.
V1.3	2024/12/13	Added distinction between DALI and 3-in-1
V1.4	2025/9/16	Modify the dimming description at the midpoint of TIM
V1.5	2026/2/6	Add the V2 programmer, power-on requirements and programming completion prompts